

# Pressurized Enclosure-system

# F850S

Use in Ex- Zone 1, 21, 2 and 22  
In accordance to EN 60079  
Compact - Intelligent - Economic  
BVS 06 ATEX E 088



## Characteristics

- 👉 **Compact system, mounting inside hazardous area or inside Ex p-Enclosure**
- 👉 **ATEX certificate**
  - Reliable Ex p System with new certificate according to EN 60079 : BVS 06 ATEX E 088
  - Function test acc. to EN 954-1, category 3
- 👉 **Menu guided programmable operation modes:**
  - Leakage compensation ⇔ Continuous flow
  - Digital solenoid valve ⇔ Proportional solenoid v.
- 👉 **Ex p- system containing a proportional working pressure and flow sensory**
  - No membrane switch, no screws or potentiometer to adjust pressure or flow thresholds or purging time
- 👉 **High availability because of regulated pressure and proportional valve**
  - High service reliability because of constant pressure
  - No purge medium wasting, just the exact quantity to hold pressure is needed
  - Increasing leakage caused by e.g. enclosure ageing will be balanced and therefore sudden failure will be prevented
  - Almost no flow noise and only a small protective gas consumption using a solid enclosure
- 👉 **Purging with pressure regulation**
  - Pressure sensitive parts of the enclosure, like membrane switch panels or windows, will not be overloaded
  - Purge volume accuracy is achieved by integration of the purge medium flow volume on the outlet
- 👉 **Proportional solenoid valve-technique for operation mode continuous flow**
  - Prevents overload and burst danger of the Ex p-Enclosure caused by disturbances at the outlet
- 👉 **Ex i- operation panel BT851**
  - For ergonomically use and control of the Ex p- system
- 👉 **The connection to the control unit counts only 3 wires Display**
  - On-line text messages of operation and malfunction states
  - States of pressure or flow are every time available
  - Displays menu and messages as plain text
  - Available Languages: German, English, French, Spanish, Dutch

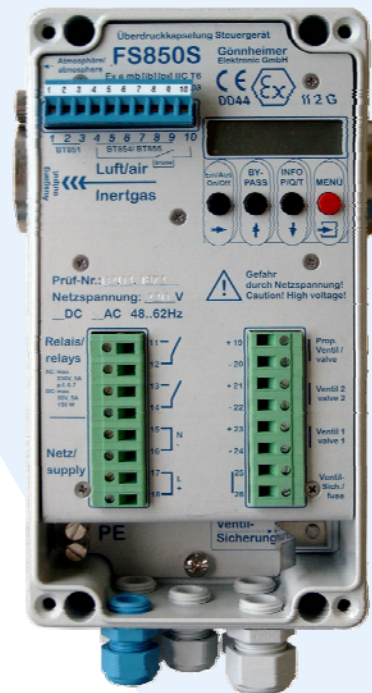

- 👉 **Terminal specifications**
  - 2-pole potential free relays terminals  
Switching capacity 250 V~, 5A , cos φ > 0,7
  - Integrated intrinsically safe interface for additional safety sensory
  - Valve fuse is exchangeable placed inside the control unit FS850S - no separate Exe- fuse box required
  - The build-in spark lattice allows to let off the purge medium direct into the hazardous area
- 👉 **High operation safety**
  - Approved function security acc. to EN 954-1, **category 3**
  - Alarm messages on LC-Display
  - Many years of Experience in pressurized enclosures according to 50016 made the development of this Ex p- system possible

## Explosion protection: pressurized enclosure

The use of pressurized enclosures provides the operation of 'non Explosion protected' devices in hazardous areas of Zone 1, 21, 2 and 22. The protection type 'pressurisation' is based on the principle of maintaining a constant pressure using air or a protective gas to prevent an explosive mixture forming near the apparatus inside the pressurized enclosure.

This is achieved by placing and operating the non Ex devices inside of an Ex p- housing. This housing has a small but constant overpressure of air or protective gas and prevents the infiltration of combustible gases or dusts.

In Zone 1 / 2, the pressurized enclosure must be purged with air or protective gas to remove any Explosive mixture that may be inside the enclosure, before the protected devices are energized. This automatic procedure is called **purging process**. This purging process is not applicable in Zone 21 and 22.

For purging, a common and a new integrating method are available:

1. Using the traditional method, purge quantity is the product of a preset minimum flow rate and time. The flow rate depends on the (air) pressure and the size of the internal nozzle (diameter 1 ...6 mm) of the valve and can be specified by matched charts. The common rule of purging must be considered: flow minimum is less than let in minus leakage loss. This purging method is named as **time based purging method**.
2. In contrast to the time based method the **integrating purging method** measures the real volume flow through the enclosure outlet and adds it up to get the real purge volume. Besides, the flow rate is monitored, dependent on the size of the plate orifice of the control unit. If the flow rate sinks below its minimum, it will be ignored and it will not contribute to volume integration. Therefore we achieve a safe and economic purging method.

The integration of the real medium stream on the outlet gains a minimizing of the purge gas consumption independent of the supply pressure. The exceeding of predefined flow rate setpoints and the associated higher purge gas consumption are no longer up to date.

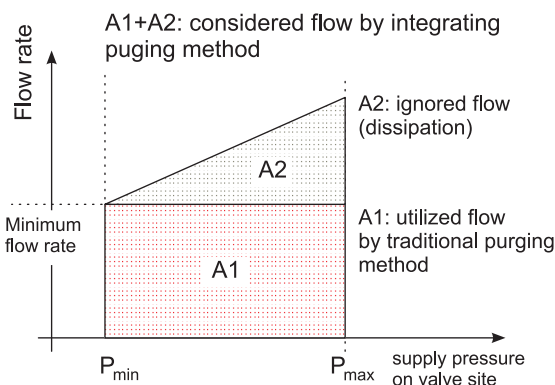

## Ex p- system F850S

The pressurized enclosure system F850S contains at least the control unit FS850S and a solenoid valve. Each can be mounted in- or outside the enclosure.

Furthermore several remote controls (operation panels) are available to improve ergonomics of operation. It is also possible to connect intrinsically safe sensors to the control unit FS850S.

The pressurized enclosure system F850S operates in two different modes: Pressurisation using leakage compensation and Pressurisation using continuous flow of protective gas.

## Leakage compensation

After purging, the control unit FS850S holds the pressure inside the enclosure on at least 0.8 mbar. The minimum and the maximum pressure of the housing are programmable and will be monitored.

The protective gas inlet is controlled in two different solenoid valve techniques: digital working solenoid valve (DSV) technique or proportional working solenoid valve (PSV) technique.

⇒ Digital solenoid valve technique

While purging, the DSV opens. After purging it is deenergized and it closes. A bypass choke compensates the leakages of the housing. This choke is integrated into the valve and is mechanical adjustable (diameter 0.3 ...1 mm).

The digital solenoid valve technique has a considerable disadvantage: while purging process and normal operation, a constant rate of protective gas is needed. Of cause of safety the rate must be bigger than leakage rate of the enclosure. The unnecessary protective gas is exhausted by the FS850S.

⇒ Proportional solenoid valve technique

Using proportional solenoid valve technique stops wasting protective gas. The internal proportional working sensory equipment and a proportional valve are combined to an input sided **pressure control system**.

The proportional valve is the actuator of a PID controller and compensates exactly the gas losses of the housing. Therefore the outlet valve of the FS850S is permanently totally closed.

Advantages of pressure feedback control are:

1. Considerable less consumption of protective gas - higher costs for prop. valve will be amortised soon
2. Increased service reliability achieved by constant pressure inside enclosure - increasing leakage caused by e.g. ageing of the enclosure will be balanced and sudden failure will be prevented
3. Almost no flow noise and only a small protective gas consumption using a solid enclosure

Another advantage using a proportional solenoid valve is; that pressure control is used even during purging. A pre defined pressure set-point controls exactly the housing pressure while the purging phase. This definite pressure conserves the pressure sensitive parts of the enclosure. Membrane switch panels or windows will not be overloaded.

## Operation mode continuous flow

The control unit FS850S supports moreover the operation mode „continuous flow“.

This operation mode is necessary, if, for example, an analyser (analyses combustible gases) could produce

an explosive atmosphere inside the enclosure (containment system).

The operation mode continuous flow purges the enclosure permanently. After the (pre-) purging process the FS850S generates a pre defined constant flow rate to dilute the possible combustibile atmosphere.

### Peripherals: Operating panels

The control unit FS850S has intrinsically safe in- and outputs to connect different safety components as well as operating and visualization panels:

These operating and visualising panels are very advantageous, particularly if the control unit is mounted inside the enclosure:

## Performance and service

The Ex p- system F850S is proved according to EN 60079 (BVS 06 ATEX E 088). The complete System, consisting of Ex p- housing - ignition- capable apparatus - Ex p- system F850S must be checked by an Ex pert of a notified body.

Gönzheimer Elektronik GmbH offers you:

- System F850S - only the components
- System F850S inclusive construction and manufacturing of a custom Ex p- housing
- The **complete Solution**: System F850S with Ex p- housing and mounting of your apparatus inclusive system test and if valid certification by the **EC type certificate DMT 02 ATEX E 086** (inclusive documentation and type sign)

**We consult you gladly, free of charge and without obligation.**

## Block diagrams

### Electrical block diagram

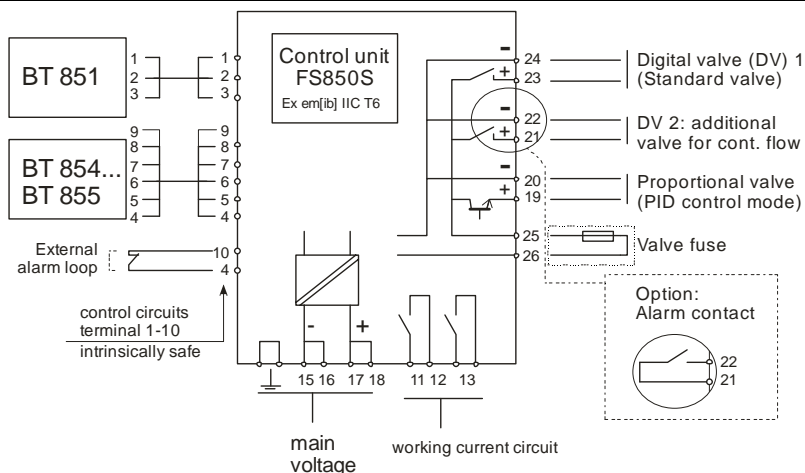

### Pneumatic block diagram

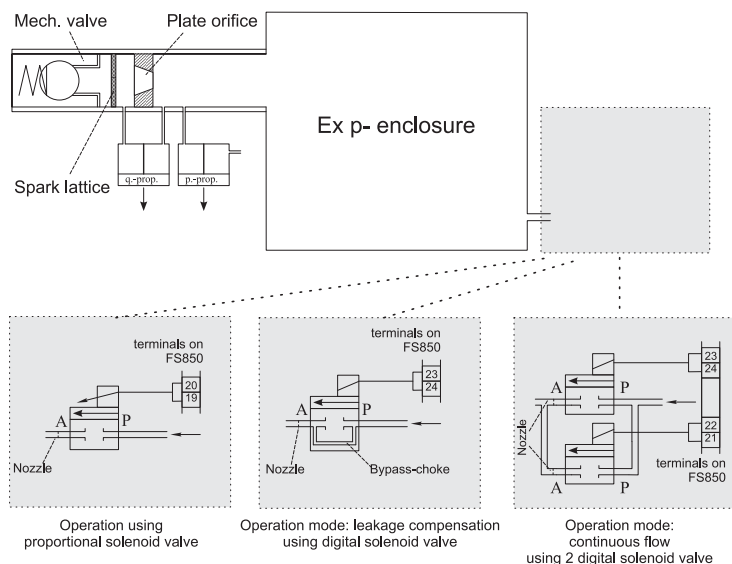

## Tables

### Plate orifice of the FS850S

Plate orifice [mm]	flow rate [m <sup>3</sup> /h]
4	0,5 ... 1,1
6	1,1 ... 2,7
10	2,5 ... 6,5
14	6 ... 11
18	9 ... 15

The suitable diameter of the plate orifice depends on the desired volume flow rate on the enclosure outlet and the built in nozzle of the solenoid valve.

Flow rates into enclosure dependent on primary pressure and nozzle diameter.

### Flow rate table, dependent on pressure and nozzle diameter

Pressure [bar] [10 <sup>5</sup> Pa]	Flow rate [l/s] $\rho_{\text{Air}} = 1.293 \text{ kg/m}^3$									
	Nozzle diameter [mm]									
	0,3	0,5	0,7	1	1,5	2	3	4	5	6
1,5	0,027	0,076	0,149	0,305	0,686	1,220	2,745	4,880	7,625	10,980
2	0,034	0,094	0,184	0,375	0,844	1,501	3,376	6,002	9,378	13,505
2,5	0,039	0,109	0,213	0,434	0,977	1,736	3,907	6,945	10,852	15,627
3	0,044	0,121	0,238	0,486	1,093	1,944	4,373	7,775	12,148	17,494
3,5	0,048	0,133	0,261	0,533	1,199	2,131	4,795	8,524	13,319	19,180
4	0,052	0,144	0,282	0,576	1,296	2,303	5,182	9,213	14,395	20,729
4,5	0,055	0,154	0,302	0,616	1,386	2,463	5,542	9,853	15,396	22,170

### Technical details

		Control unit FS850S
General	Mounting	inside hazardous area
	Ex-protection class	II 2 G, Ex e mb [ib] IIC T6 – II 2 D, Ex tD [ibD] [pD] A21 IP65 T 70°C
	Environment protection	IP 65 (Remark: without considering outlet drill)
Housing	Dimensions	H x W x D: 220 mm x 120 mm x 90 mm
	Material	Aluminium, lacquered / Ral 7035
Electrical specifications	Power consumption	about 2.5 VA (without peripherals)
	Main voltage	24VDC, 110VAC, 120VAC, 220VAC, 230VAC 48 ...62 Hz
	Working circuits clamps 11, 12, 13, 14	AC: $U \leq 250\text{VAC}$ , $I \leq 5\text{A}$ at $\cos \varphi > 0,7$ DC: $U \leq 30 \text{ VDC}$ , $I \leq 5 \text{ A}$ , $P \leq 150 \text{ W}$
	Control circuits Terminal 1..10	Ex protection class: intrinsically safe Ex ib IIC see declaration of conformity for further details BVS 06 ATEX E 088
Pneumatic	Pressure range	0 ... 18 mbar
	Flow rate range	dependent on plate orifice, see table above
Mounting	Position	Inlet and outlet of the control unit should be lined up on a horizontal axis.
	Environment temperature	-10°C ...+50°C at T6 -10°C ...+60°C at T4
Ex p Configuration	Parameter input	LC-Display, menu guided Different languages : German, English, French, Spanish, Dutch
	Storage	Permanently failure proved in EEPROM

# Dimensions

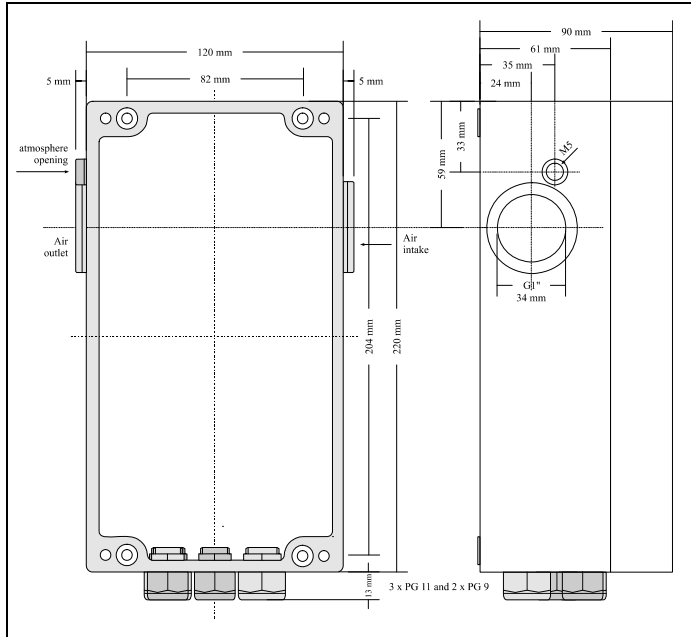

**Figure 1: Dimensions FS850S**

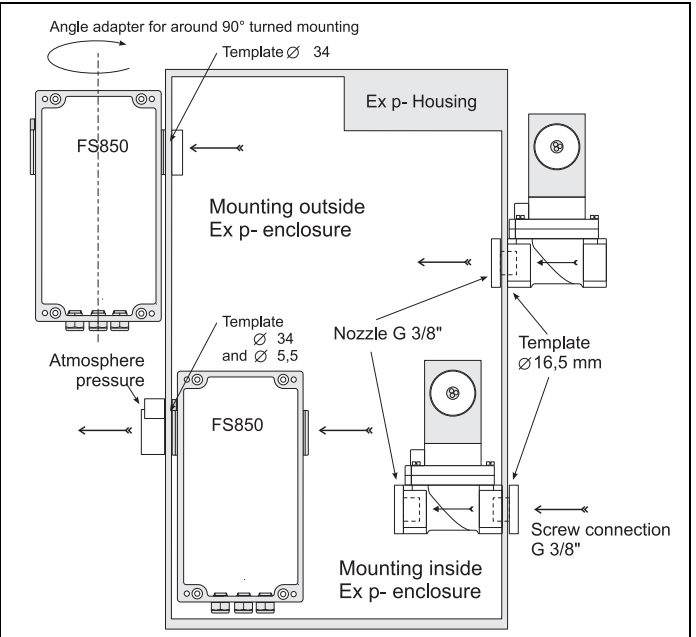

**Figure 2: Mounting examples**

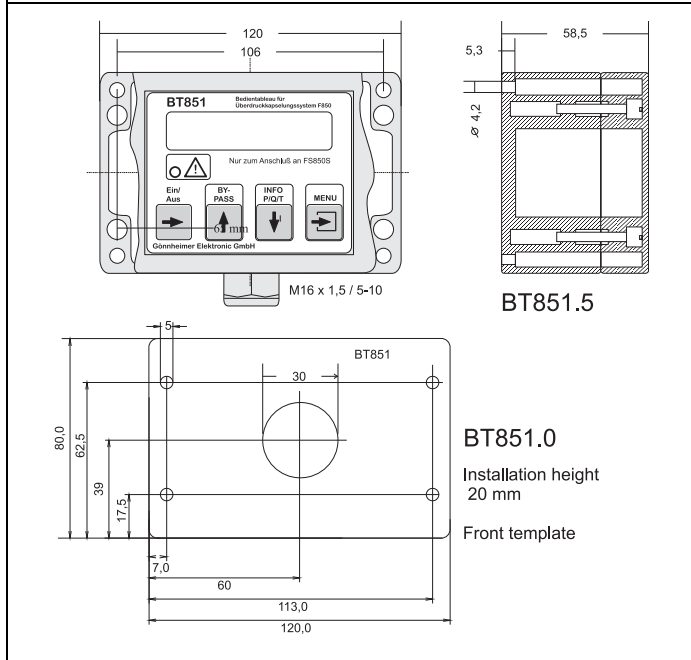

**Figure 3: Dimensions and template BT851**

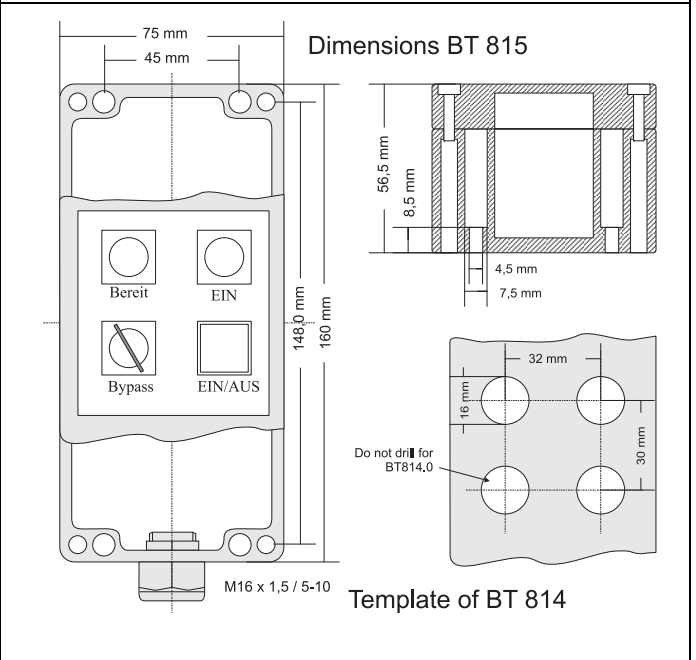

**Figure 4: Dimensions BT855, template BT854**

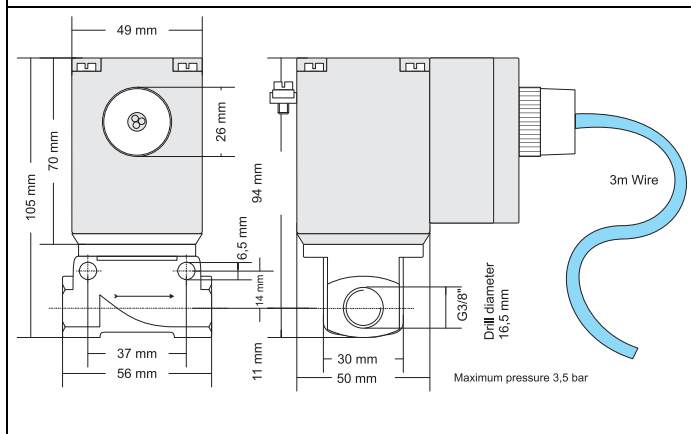

**Figure 5: Dimensions digital solenoid valve**

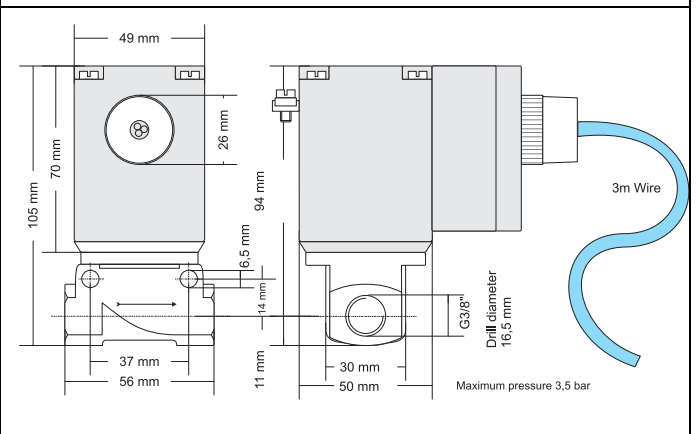

**Figure 6: Dimensions proportional solenoid valve**

## Type code

<b>Control unit FS850S</b>		.	.
Mains voltage: 230 VAC .....		.0	
24 VDC .....		.6	
Plate orifice: 4 mm, range 0.5 ...1,1 m <sup>3</sup> /h.....		.0	
6 mm, range 1.1 ...2,7 m <sup>3</sup> /h.....		.2	
10 mm, range 2.5 ...6,5 m <sup>3</sup> /h .....		.4	
14 mm, range 6 ...11 m <sup>3</sup> /h .....		.6	
18 mm, range 9 ...15 m <sup>3</sup> /h.....		.8	

**Accessories:** Additive window in control unit FS850S (recommendable, if no operation panel is used)

<b>Operation panels</b>	<b>BT</b>
Intelligent operation panel, Ex ib IIC T6, for mounting on the front	<b>BT851.0</b>
Intelligent operation panel, Ex ib IIC T6, with IP65 housing	<b>BT851.5</b>
Operation panel, Ex ib IIC T6, for mounting on the front	<b>BT854.0</b>
with key-operated switch	<b>BT854.1</b>
Operation panel, Ex ib IIC T6, with IP65 housing	<b>BT855.0</b>
with key-operated switch	<b>BT855.1</b>

<b>Purge medium valve:</b>		(Ex de IIC T4)	
<i>Digital</i>	<b>SVD</b>	.	.
Continuous flow .....		.D	
Leakage compensation ..		.L	
Nozzle: 1 mm .....		.1	
1,5 mm .....		.1.5	
2 mm .....		.2	
3 mm .....		.3	
4 mm .....		.4	
5 mm .....		.5	
6mm .....		.6	
		<i>Proportional, suitable for Ex p-housing size</i>	
		<b>SVP</b>	
		Up to 300 l .....	.3
		bigger than 300l ...	.5

Order mains voltage in plain text (e.g.SVD.L.2 24VDC)

<b>Fuse for solenoid valve</b>			Nominal	Order.Nr
(Ex-version)			100 mA	<b>SI850.0</b>
U <sub>Nominal</sub>	SVP	SVD	160mA	<b>SI850.1</b>
230 VAC, 220 VAC	200mA	100mA	200 mA	<b>SI850.2</b>
120 VAC, 110 VAC	315mA	160mA	315 mA	<b>SI850.3</b>
24 VAC, 24 VDC	1,6 A	630mA	500 mA	<b>SI850.4</b>
			630 mA	<b>SI850.5</b>
			1000 mA	<b>SI850.6</b>
			1600 mA	<b>SI850.7</b>
			2000mA	<b>SI850.8</b>

Remark: please order the Ex- solenoid valve fuse separately

## Maximum fuse data dependent on main voltage

Main voltage U <sub>N</sub>	Maximum fuse current
230 V	200 mA
220 V	250 mA
120 V	315 mA
110 V	500 mA
24 V	2000 mA

To get the correct solenoid valve fuse comply the table above 'Fuse for solenoid valve'.

If you want to use an other solenoid valve, with different fuse data, it is important to consider the maximum values in the table on the left side. By each main voltage a safety maximum current rate is given.

Example: The main voltage is 220 V. In this case the maximum fuse current is 250 mA.

## Ex p- housings on request

	<b>Gönnheimer Elektronik GmbH</b>		Dr.-Julius-Leber-Straße 2 67433 Neustadt/Weinstraße Postfach 10 05 07 67405 Neustadt, Germany phone: +49 (6321) 49919- 0 fax: +49 (6321) 49919 - 41
	<a href="http://www.goennheimer.de">http://www.goennheimer.de</a> Email: <a href="mailto:info@goennheimer.de">info@goennheimer.de</a>		