

# Ex- WLAN Access Point AP170

Combined gas and dust explosion proof  
Direct mounting in hazardous area  
Data rate 54 Mbps / 108 Mbps



## Characteristics

- 👉 **Ex- Protection**
  - II 2 G; EEx e q IIC T4
  - II 2 D; II 2 D; Ex tD A21 IP65 T135°C
- 👉 **IEEE 802.3af Power over Ethernet (PoE)**
  - No additional power supply
  - Simple Installation
- 👉 **Designed for industrial area**
  - Robust aluminium housing (optional polyester)
  - Housing protection IP65
- 👉 **IEEE 802.11g - Standard**
  - Highest data rates
  - High flexibility, downwards compatible
- 👉 **High safety standard**
  - 64/128/152 Bit WEP data encryption
  - WPA data encryption
- 👉 **Advantages of wireless communication net:**
  - Cost saving Installation
  - Highest flexibility in plant operation
  - Simple factory reconfiguration
  - Mobile applications
  - Simple diagnosis / maintenance reduces service costs and idle periods
  - Plant specific information at any place and any time



## Description

The AP170 is a WLAN ACCESS POINT for Industrial Ethernet in hazardous areas Zone 1, 21, 2 and 22.

The AP170 provides an efficient area and cell network in industrial environment according to standard IEEE 802.3 (ETHERNET) and IEEE 802.11 (Wireless LAN).

The various possibilities of Internet and Intranet, already existing in office and industrial area today, are now also available in hazardous areas of manufacturing and process automation.

The AP170 also available with separated antennas. On this option must be considered that the signal gets attenuated through the cable and the range of the AP170 will be limited.

## Technical Details

		WLAN Access Point AP170	
General	Mounting	Inside Ex-area	
	Ex-protection	II 2 G, EEx e q IIC T4	- II 2 D, Ex tD A21 IP65 T135°C
Housing	Dimensions	H x B x T: 280 mm x 200 mm x 80 mm	
	Protection class	IP65	
	Material	Aluminum, lacquered / Ral 7035	
Electrical Specification	Mains	PoE (Power over Ethernet) (optional: separate mains terminals)	
	Power consumption	Aprox. 14 W	
	Wireless frequency range	2,4 GHz...2,4835 GHz	
	Data rate	54 MBit/s, Standard 802.11g, 108 MBit/s	
Mounting	Ambient temperature	-20°C ...+50°C	

## Type code

WLAN Access Point AP170	.	.
AP- version:	.	.n
Antenna connection:		
Mounted outside AP170 .....	.	.0
Wire connection to AP170* .....	.	.2

\*: Specify cable length in clear text (standard: 1m)

## Block diagram

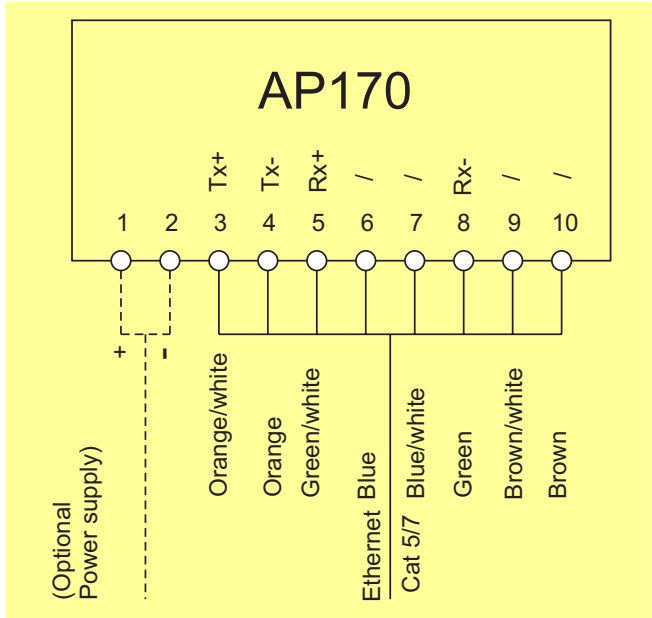

## Dimensions

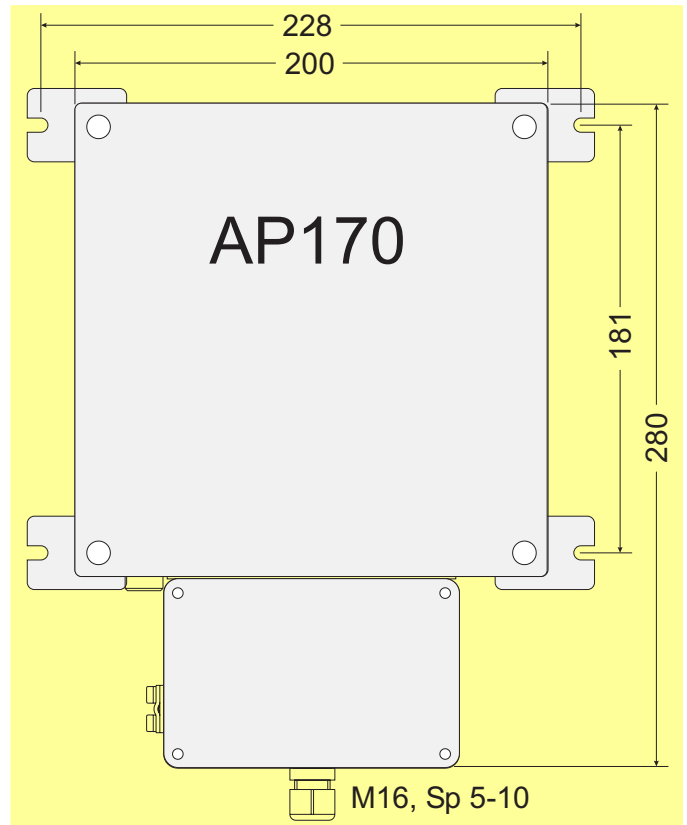

Housing height: 80 mm

## Application

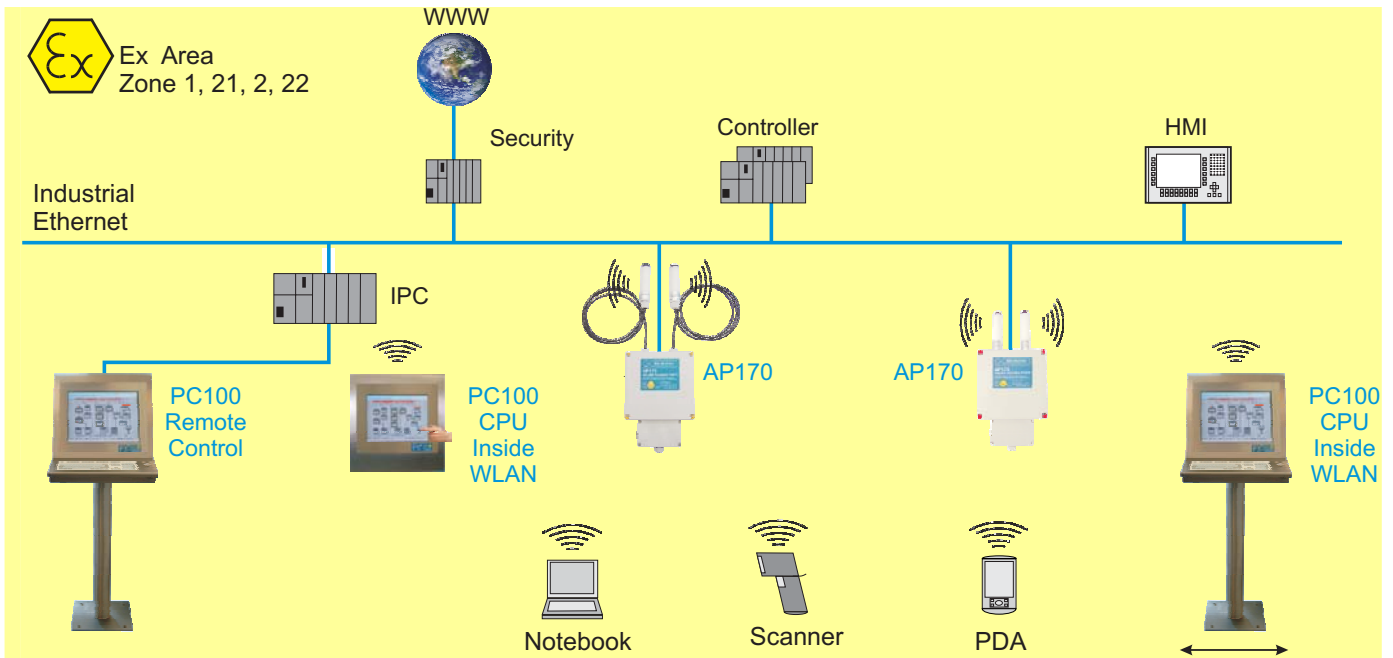



# Gönnheimer Elektronik GmbH

http://www.goennheimer.de Email: info@goennheimer.de

Zertifiziertes

**Qualitäts-**

Managementsystem  
nach  
DIN EN ISO 9001

Dr.-Julius-Leber-Straße 2  
67433 Neustadt/Weinstraße  
Postfach 10 05 07  
67405 Neustadt  
phone: +49 (6321) 49919- 0  
fax: +49 (6321) 49919 - 41