



BM 26 Technical Datasheet

Bypass Level Indicator

- Most compact bypass level indicator on the market
- Robust, stainless steel design
- Permanent, IP68 local indication without power supply



The proven mechanical-based solution for level indication

The **BM 26** is a simple, rugged instrument designed to indicate level or interface. It indicates level using a float magnetically coupled to an index or a column of rotating flaps. It is ideal for aggressive media stored in tanks when the PTFE lining option is used.

For liquids with densities less than 0.5 kg/l / 31 lb/ft³, pressures more than 120 bar / 1740 psig and temperatures higher than 300°C / 570 °F, we recommend our BW 25 displacer-type level indicator.

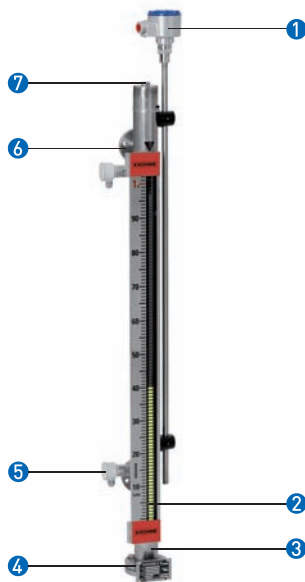

- ① Option: level transducer
- ② IP 68 level indicator (pyrex tube with an index or a column of rotating flaps)
- ③ Stainless steel bypass chamber (316 L or 316 Ti), with optional PTFE lining for acids
- ④ Option: drain with plug or flange connection
- ⑤ Option: limit switches
- ⑥ Versions: side or inline process connections (with loose or welding neck flanges)
- ⑦ Option: vent with plug or flange connection

Highlights

- Stainless steel design (optional NACE conformity)
- Proven technology
- Temperature range: -200...+300°C / -325...+570°F
- Pressure range: -1...120 bar / -14.5...1740 psig
- Density: 0.5...3 kg/l / 31...187 lb/ft³
- Float material options: 316L, 316 Ti and Titanium
- Stainless steel scale with wide choice of markings: m/cm, ft/in, %, volume etc.
- Less risk of leakage than a sight glass - little or no maintenance needed
- Easy to install
- Ideal for tanks with obstructed environments
- Optional indication of interface
- Optional approvals for EEx i or EEx d applications

Industries

- Chemical and Petrochemical
- Oil and Gas
- Power

Applications

- Boilers
- Condensators
- Hydrocarbons and Separators
- Liquid gas
- Process and storage tanks
- Steam cracking

A simpler and cheaper alternative for your application

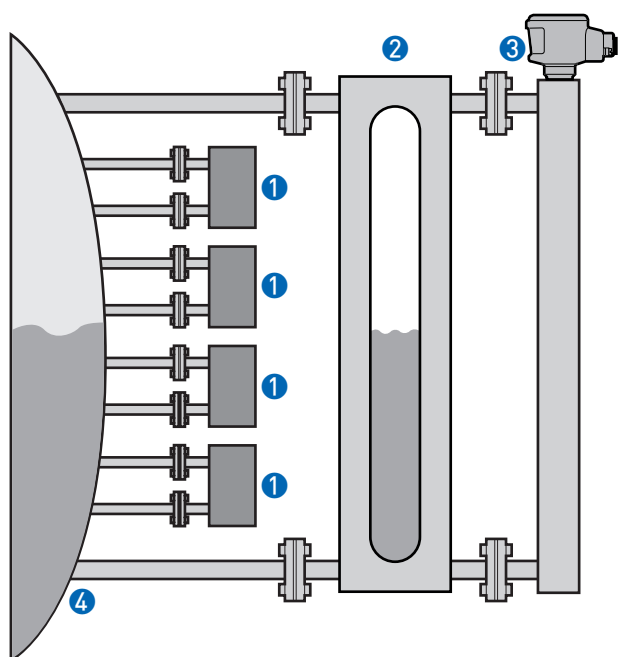

An example of a typical industrial application

Level indication on large tanks often involves a complex arrangement of devices set up to indicate level and provide an analogue output.

- 1. Small bypass or displacer-type level indicators in a series arrangement
- 2. Sight glass
- 3. Bypass chamber with analogue output
- 4. Tank

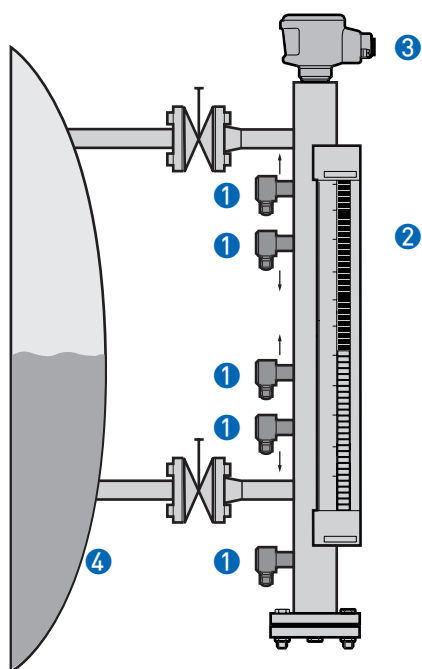

KROHNE's all-in-one equivalent using the BM 26

The BM 26 is a bypass level indicator that provides you with an all-in-one alternative. You only need one BM 26 to read level locally or remotely, integrate the instrument into a network and receive alarms at critical points (tank full, sunk float etc).

- 1. Limit switches in high-high, high, low, low-low and sink detection positions. The user can adjust these positions on-site.
- 2. Bypass level indicator (magnetic)
- 3. Level transducer with analogue or network output
- 4. Tank

Technical data: general information

	BM 26 A	BM 26 PTFE-lined
--	---------	------------------

Input

Device	Magnetic level indicator	
Function	Float magnetically coupled to a mechanical level indicator	
Parameter	Level, interface, or volume	
Max. measuring range	0.3...6 m / 1...20 ft ①	0.3...5.5 m / 1...18 ft ①

Output

Output signal	see "Technical data: optional level transducer" (if option fitted)	
Error signal	see "Technical data: optional level transducer" (if option fitted)	

Accuracy

Repeatability	±10 mm / ±0.4"	
Accuracy	±10 mm / ±0.4"	

Process conditions

Ambient temperature	-40...+85°C / -40...+185°F; Ex i: see supplementary operating instructions or approval certificates	-20...+85°C / -4...+185°F
Storage temperature	-40...+85°C / -40...+185°F	
Process temperature	-40...+200°C / -40...+390°F; Ex i: see supplementary operating instructions or approval certificates ②	-20...+200°C / -40...+390°F
Thermal resistance	100°C/min / 210°F/min	
Operating pressure	-1...40 bar / -14.5...580 psig ③	0...10 bar / 0...145 psig ③
Product density	0.5...3 kg/l / 31...187 lb/ft³	
Viscosity	≤5000 mPas / ≤3.360 lb/fts	
Protection category	IP 68 equivalent to NEMA 6-6X	

	BM 26 A	BM 26 PTFE-lined
--	----------------	-------------------------

Material

Chamber	Stainless steel (1.4404 / 316L); Stainless steel (1.4571 / 316Ti)	Stainless steel (1.4404 / 316L) with PTFE lining
Float	Stainless steel (1.4404 / 316L); Stainless steel (1.4571 / 316Ti); Titanium	Glass; PTFE
Indicator tube	Pyrex glass	
Scale	Stainless steel	
Process fitting	Stainless steel (1.4404 / 316L); Stainless steel (1.4571 / 316Ti)	Stainless steel (1.4404 / 316L) with PTFE lining
Gaskets	Klingerit; PTFE	PTFE
Heater casing	Stainless steel (1.4404 / 316L) ④	-
Insulation	Glass fibre wool ⑤	-
Magnifier glass	Plexitherm glass ⑥	-

Process connections

Loose flange	DN15...50 (PN40) ①	-
Welding Neck flange	DN15...50 (PN40); ½"...2" (150 lb / 300 lb) ①	DN25...50 (PN10); 1"...2" (150 lb) ①

Drain and vent connections

Thread	G or NPT 3/8; G or NPT 1/2; NPT 3/4	NPT 1/2
Flange	DN15, 25 PN40; 1/2"...1" (150 lb/300 lb)	DN15...25 (PN16); 1/2"...1" (150 lb)

Display

Display options	Indicator column - magnetically-coupled floating index
	Indicator column - magnetically coupled, yellow/black rotating flaps
	Scale markings: m+cm; ft+in; or % ⑦

Design codes

Conformity to pressure equipment directives	PED 97/23/EC	
Pressure vessel construction code	CODAP® 2005	
Options	NACE MR0175 / ISO 15156	-

	BM 26 A	BM 26 PTFE-lined
--	----------------	-------------------------

Approvals

ATEX	ATEX II 1/2 G EEx d IIC T3...T6; ATEX II 1/2 G EEx d ia IIC T3...T6; ATEX II 1 G EEx ia IIC T3...T6	
------	---	--

Variants, options and accessories

Variants	C: two side connections	C: two side connections
	D: two inline connections	-
	E: top side connection and bottom inline connection	-
	F: top inline connection and bottom side connection	-
Sub-variants	Standard	
	AG / long connection AG: low temperature (min -40°C / -40°F)	-
	B: With heating/cooling system ④	-
	TR: very low-temperature (min.-200°C / -330°F)	-
	IC/TR: very low-temperature, with insulation jacket (min.-200°C / -330°F)	-
	HR: high-temperature (+200...+300°C / +390...570°F)	-
	IC/HR: high-temperature, with insulation jacket (+200...+300°C / +390...570°F)	-
Options	Level transducer	
	Limit switches	
Accessories	Insulation jacket ⑨	-

① other sizes on request

② Optional non-Ex -200...+300°C / -325...+570°F

③ subject to process connection used and flange temperature; information on higher pressure levels available on request

④ for the heating/cooling system sub-variant (B)

⑤ for the insulated high-temperature sub-variant (IC/HR) or the insulated very low-temperature sub-variant (IC/TR)

⑥ for the low temperature sub-variant (AG)

⑦ volume units on request

⑧ 2 DN15 connections - or optionally tubes for Ermeto 12 connectors - are provided for the heat transfer fluid

⑨ for indicators with long process connections

Technical data: optional level transducer

	PR 5343B 4...20 mA output	PR 5350B PROFIBUS PA® or FF output	PR 5335B 4...20 mA/HART® output
--	------------------------------	--	------------------------------------

Input

Device	Level transducer (column of reed resistors connected to a transmitter module) mounted on the side of the BM 26 bypass chamber
Function	Reed-chain magnetically actuated by float in BM 26 bypass chamber
Parameter	Level
Max. measuring range	0.3...6 m / 1...20 ft

Output

Output signal	4...20 mA	PROFIBUS® PA protocol Profile A&B, ver. 3.0 (EN 50710 vol.2) or FOUNDATION™ Fieldbus protocol	4...20 mA/HART
Error signal	High: 23 mA; Low: 3.5 mA	-	High: 23 mA; Low: 3.5 mA

Accuracy

Repeatability	±10 mm / ±0.4"
Accuracy	±10 mm / ±0.4"

Process conditions

Ambient temperature	-40...+85°C / -40...+185°F; EEx i: see supplementary operating instructions or approval certificates
Process temperature	-40...+200°C / -40...+390°F; EEx i: see supplementary operating instructions or approval certificates ①
Protection category	IP 65 equivalent to NEMA 4-4X
Electromagnetic compatibility (EMC)	EN 61326 89/336/EEC (EMC Directive) 2006/95/EC (Low Voltage Directive)

Material

Transmitter module housing	Aluminium
Probe	Stainless steel (1.4404 / 316L)
Bracket	Aluminium (stainless steel for high-temperature versions)
Clamp	Stainless steel

Electrical connections

Instrument terminal - non Ex	8...35 VDC ②	9...32 VDC	8...35 VDC ②
Instrument terminal - EEx	8...30 VDC ②	9...30 VDC	8...30 VDC ②
Maximum safety values ③	See supplementary operating instructions or approval certificates		
Cable entry	M20 x 1.5, M25 x 1.5 or NPT¼ ④		

	<p>PR 5343B 4...20 mA output</p>	<p>PR 5350B PROFIBUS PA® or FF output</p>	<p>PR 5335B 4...20 mA/HART® output</p>
--	--------------------------------------	---	--

Approvals

ATEX	<p>ATEX II 1/2 G EEx d IIC T3...T6 or ATEX II 1/2 G EEx d ia IIC T3...T6; ATEX II 1 G EEx ia IIC T3...T6</p>
------	--

- ① for HR versions: +300°C / 570°F
- ② min./max. value for an output of 23 mA at the terminal
- ③ for EEx i applications
- ④ Cable fitting is not supplied: only use fittings and other components that are EEx-certified, if EEx i or EEx d approval is chosen

Technical data: optional level switches

	Standard (Non-Ex) switches					
Type code	MS20 STD/LC/PC/NN /BT	MS15 STD/LC/PC/NO /BT	MS15 STD/LC/AL/NN /HT	MS15 STD/LC/AL/NO/ HT	MS15 STD/HC/PC/NN /BT	MS15 STD/HC/AL/NN /HT
Version	Low price, standard	NAMUR	High- temperature	NAMUR, high- temperature	High-power cut-out	High-power cut-out, high temperature

Input

Device	Level switch mounted on the side of the BM 26 bypass chamber					
Function	Reed switch that is magnetically actuated by float in BM 26 bypass chamber					
Parameter	Level detection					
Switching capacity	30 VA; 0.5 A; 230 VAC	①	20 VA; 1.5 A; 250 VAC	②	3...100VA 1.5 A; 250 VAC	3...100VA 1.5 A; 250 VAC

Accuracy

Hysteresis	Not applicable
------------	----------------

Process conditions

Ambient temperature	-20...+120°C / -4...+250°F ③					
Process temperature	-40...+250°C / -40...+480°F	-40...+250°C / -40...+480°F	-40...+300°C / -40...+570°F	-40...+300°C / -40...+570°F	-40...+250°C / -40...+480°F	-40...+300°C / -40...+570°F
Protection category	IP 65 equivalent to NEMA 4-4X					

Material

Switch housing	Polycarbonate	Polycarbonate	Aluminium	Aluminium	Polycarbonate	Aluminium
Bracket	Stainless steel					
Clamp	Stainless steel					

Electrical connections

Cable entry	PG 9	PG 13.5	M20 x 1.5 ④	M20 x 1.5 ④	PG 13.5	M20 x 1.5 ⑤
-------------	------	---------	-------------	-------------	---------	-------------

- ① according to NAMUR 19234. Connect to a NAMUR amplifier.
- ② according to NAMUR 19234. Connect to a NAMUR amplifier.
- ③ specify temperature if an insulation jacket is used
- ④ Optional: M25 x 1.5 or NPT $\frac{1}{4}$. Cable fitting not supplied.
- ⑤ Optional: M25 x 1.5 or NPT $\frac{1}{4}$. Cable fitting not supplied.

	Exi-approved switches			
Type code	MS20 EXI/LC/PC/NN/BT	MS15 EXI/LC/PC/NO/BT	MS15 EXI/LC/AL/NN/HT	MS15 EXI/LC/AL/NO/HT
Version	low price, standard	NAMUR	high-temperature	NAMUR, high-temperature

Input

Device	Level switch mounted on the side of the BM 26 bypass chamber			
Function	Reed switch that is magnetically actuated by float in BM 26 bypass chamber			
Parameter	Level detection			
Switching capacity	0.5 A ①	②	1.5 A ①	②

Accuracy

Hysteresis	Not applicable
------------	----------------

Process conditions

Ambient temperature	③			
Process temperature	③	③	③	③
Protection category	IP 65 equivalent to NEMA 4-4X			

Material

Switch housing	Polycarbonate	Polycarbonate	Aluminium	Aluminium
Bracket	Stainless steel			
Clamp	Stainless steel			

Electrical connections

Power supply characteristics	See supplementary operating instructions or approval certificates.			
Cable entry	PG 9	PG 13.5	M20 x 1.5 ④	M20 x 1.5 ④

Approvals

ATEX	ATEX II 1 G EEx ia IIC T3...T6
------	--------------------------------

- ① Only connect to a certified intrinsically-safe power supply. Safety values: see supplementary operating instructions or approval certificates.
- ② according to NAMUR 19234. Connect a NAMUR amplifier.
- ③ Dependant on temperature class: see supplementary operating instructions or approval certificates.
- ④ Optional: M25 x 1.5 or NPT½. Cable fitting not supplied.

	Exd-approved switches		
Type code	MS15 EXD/LC/AL/NN/HT	MS15 EXD/LC/AL/NO/HT	MS15 EXD/HC/AL/NN/HT
Version	high-temperature	NAMUR, high-temperature	high-power cut-out, high-temperature

Input

Device	Level switch mounted on the side of the BM 26 bypass chamber		
Function	Reed switch that is magnetically actuated by float in BM 26 bypass chamber		
Parameter	Level detection		
Switching capacity	20 VA; 1.5 A; 250 VAC	①	1.5 A ②

Accuracy

Hysteresis	Not applicable
------------	----------------

Process conditions

Ambient temperature	③		
Process temperature	④	④	④
Protection category	IP 65 equivalent to NEMA 4-4X		

Material

Switch housing	Aluminium	Aluminium	Aluminium
Bracket	Stainless steel		
Clamp	Stainless steel		

Electrical connections

Cable entry	M20 x 1.5 ⑤	M20 x 1.5 ⑤	M20 x 1.5 ⑤
-------------	-------------	-------------	-------------

Approvals

ATEX	ATEX II 1/2 G EEx d ia IIC T3...T6
------	------------------------------------

① according to NAMUR 19234. Connect a NAMUR amplifier.

② Only connect to a certified intrinsically-safe power supply. Safety values: see supplementary operating instructions or approval certificates.

③ Dependant on temperature class: see supplementary operating instructions or approval certificates.

④ Dependant on temperature class: see supplementary operating instructions or approval certificates.

⑤ Optional: M25 x 1.5 or NPT%. Cable fitting not supplied.

Dimensions and Weights

Variant C: two side process connections

Standard, low-temperature (AG), and high-temperature (HR) sub-variants

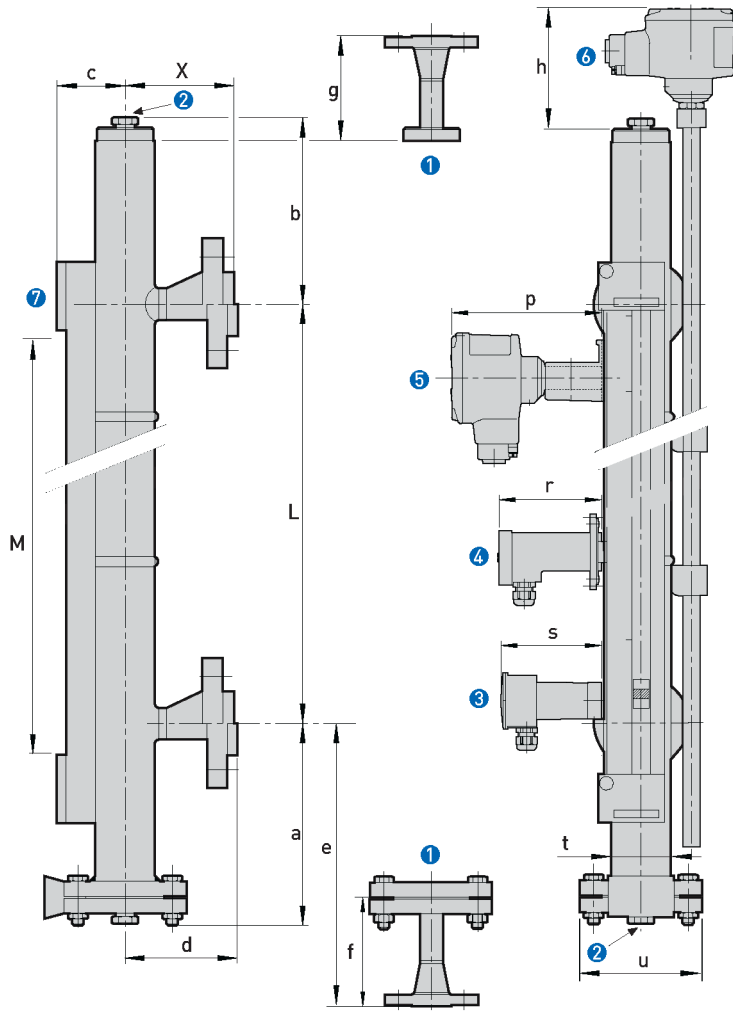

- ① Optional drain or vent with flange connection
- ② Optional drain or vent with G or NPT plug
- ③ Optional MS20 limit switch
- ④ Optional MS15 limit switch for low-temperature applications
- ⑤ Optional MS15 limit switch for high-temperature and Ex d applications
- ⑥ Optional level transducer
- ⑦ Low temperature sub-variant (AG): Indicating tube with plexitherm glass cover (prevents condensation forming on indicating tube)
High-temperature sub-variant (HR): High-temperature indicating tube with floating index

Dimensions in mm

	Dimensions [mm]															
	a	X	b	L	M	c	d	e	f	g	h	p	r	s	t	u
Sub-variants: Standard AG HR	300	①	200	300 ... 6000	②	72 ③	115 ④	375	116	116	150 ... 170 ⑤	146 ⑥	100 ⑦	98 ⑧	Ø72 x 2.3	Ø130

- ① Standard connections: according to process connection size. See the "Process connection dimension X" table at the end of this section.
Long connections: 165 mm
- ② this is the measuring range of the indicator column. It is equal to the dimension L.
- ③ 100 mm for low-temperature sub-variant
- ④ 165 mm for long connections
- ⑤ with optional level transducer
- ⑥ with optional MS15 limit switch for high-temperature and Ex d applications
- ⑦ with optional MS15 limit switch for low-temperature applications
- ⑧ with optional MS20 limit switch

Dimensions in inches

	Dimensions [inches]															
	a	X	b	L	M	c	d	e	f	g	h	p	r	s	t	u
Sub-variants: Standard AG HR	12.0	①	7.9	12 ... 236	②	2.8 ③	4.5 ④	14.8	4.6	4.6	6 ... 6.7 ⑤	5.7 ⑥	4.0 ⑦	3.9 ⑧	Ø2.8 x 0.09	Ø5.1

- ① Standard connections: according to process connection size. See the "Process connection dimension X" table at the end of this section.
Long connections: 6.5"
- ② this is the measuring range of the indicator column. It is equal to the dimension L.
- ③ 3.9" for low-temperature sub-variant
- ④ 6.5" for long connections
- ⑤ with optional level transducer
- ⑥ with optional MS15 limit switch for high-temperature and Ex d applications
- ⑦ with optional MS15 limit switch for low-temperature applications
- ⑧ with optional MS20 limit switch

Weight in kg and lbs

	Weight when L=1000 mm	Weight when L=40 inches	Weight for every additional 100 mm	Weight for every additional 4 inches
	[kg]	[lbs]	[kg]	[lbs]
Bypass chamber	14.5	32.0	0.5	1.1
Level transducer	2.3	5.1	0.1	0.2
MS15 BT limit switch ①	0.13	0.3		
MS15 HT limit switch ②	1.2	2.6		
MS20 limit switch	0.085	0.2		

- ① for low-temperature applications
- ② for high-temperature applications

Heating/cooling system sub-variant (B)

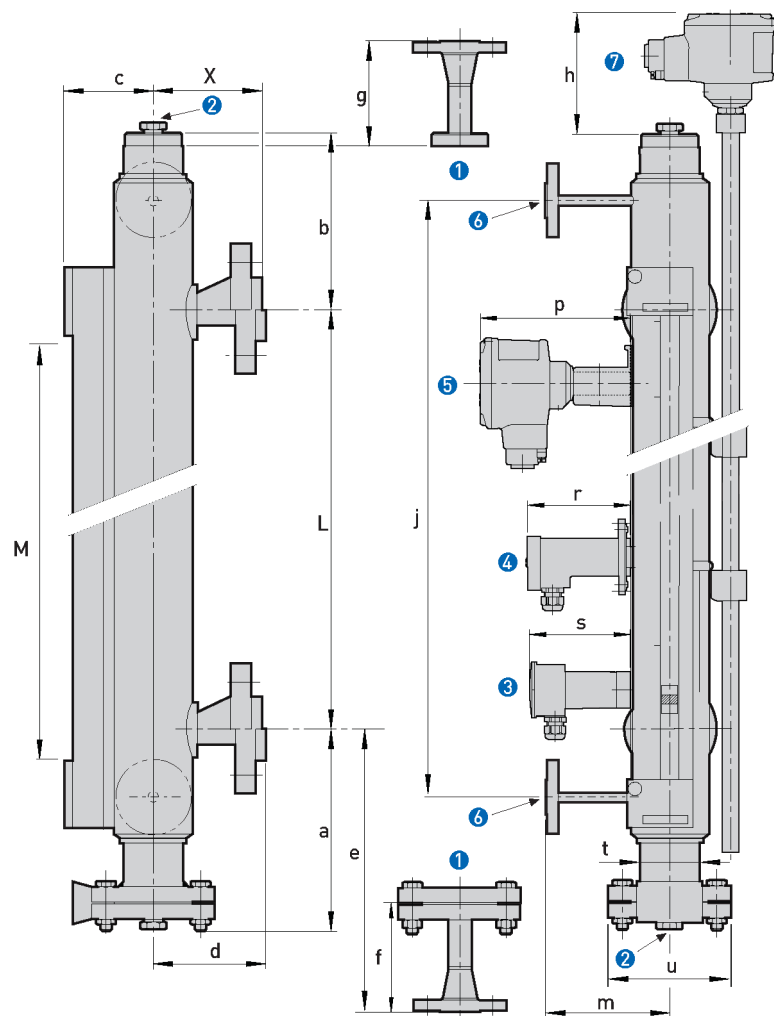

- ① Optional drain or vent with flange connection
- ② Optional drain or vent with G or NPT plug
- ③ Optional MS20 limit switch
- ④ Optional MS15 limit switch for low-temperature applications
- ⑤ Optional MS15 limit switch for high-temperature and Ex d applications
- ⑥ Heating system inlet/outlet. Options: DN15 PN40 flange connection or tube for Ermeto 12
- ⑦ Optional level transducer

Dimensions in mm

	Dimensions [mm]																	
	a	X	b	L	M	c	d	e	f	g	h	j	m	p	r	s	t	u
Sub-variant: B	300	165	200	300 ... 6000	①	76	165	375	116	116	150 ... 170 ②	L+ 304	165 ③	146 ④	100 ⑤	98 ⑥	Ø72 x 2.3	Ø130

- ① this is the measuring range of the indicator column. It is equal to the dimension L.
- ② with optional level transducer
- ③ 100 mm for optional tube for Ermoto 12 connection
- ④ with optional MS15 limit switch for high-temperature and Ex d applications
- ⑤ with optional MS15 limit switch for low-temperature applications
- ⑥ with optional MS20 limit switch

Dimensions in inches

	Dimensions [inches]																	
	a	X	b	L	M	c	d	e	f	g	h	j	m	p	r	s	t	u
Sub-variant: B	12.0	6.5	7.9	12 ... 236	①	3.0	6.5	14.8	4.6	4.6	6 ... 6.7 ②	L+ 12.0	6.5 ③	5.7 ④	4.0 ⑤	3.9 ⑥	Ø2.8 x 0.09	Ø5.1

- ① this is the measuring range of the indicator column. It is equal to the dimension L.
- ② with optional level transducer
- ③ 4.0" for optional tube for Ermoto 12 connection
- ④ with optional MS15 limit switch for high-temperature and Ex d applications
- ⑤ with optional MS15 limit switch for low-temperature applications
- ⑥ with optional MS20 limit switch

Weight in kg and lbs

	Weight when L=1000 mm	Weight when L=40 inches	Weight for every additional 100 mm	Weight for every additional 4 inches
	[kg]	[lbs]	[kg]	[lbs]
Bypass chamber	14.5	32.0	0.5	1.1
Level transducer	2.3	5.1	0.1	0.2
MS15 BT limit switch ①	0.13	0.3		
MS15 HT limit switch ②	1.2	2.6		
MS20 limit switch	0.085	0.2		

- ① for low-temperature applications
- ② for high-temperature applications

Insulated high-temperature (IC/HR) and insulated very low-temperature (IC/TR) sub-variants

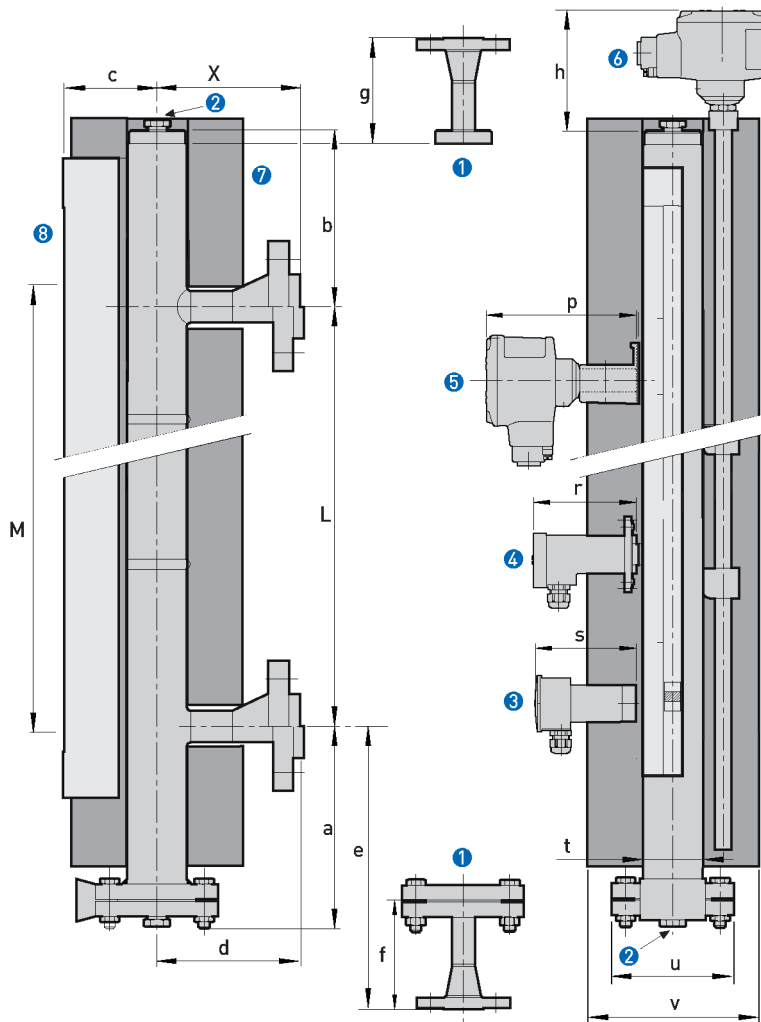

- 1 Optional drain or vent with flange connection
- 2 Optional drain or vent with G or NPT plug
- 3 Optional MS20 limit switch
- 4 Optional MS15 limit switch for low-temperature applications
- 5 Optional MS15 limit switch for high-temperature and Ex d applications
- 6 Optional level transducer
- 7 Optional insulation jacket
- 8 Insulated high-temperature sub-variant (IC/HR): high-temperature indicating tube with floating index
 Insulated very low-temperature sub-variant (IC/TR): indicating tube with plexitherm glass cover (magnifies indicator and prevents condensation forming on the indicating tube)

Dimensions in mm

	Dimensions [mm]																
	a	X	b	L	M	c	d	e	f	g	h	p	r	s	t	u	v
Sub-variants: IC/HR IC/TR	300	165	200	300 ... 6000	①	100 ②	165	375	116	116	150... 170 ③	146 ④	100 ⑤	98 ⑥	Ø72 x 2.3	Ø130	Ø200

- ① this is the measuring range of the indicator column. It is equal to the dimension L.
- ② for IC/HR sub-variant. IC/TR sub-variant: 116 mm.
- ③ with optional level transducer
- ④ with optional MS15 limit switch for high-temperature and Ex d applications
- ⑤ with optional MS15 limit switch for low-temperature applications
- ⑥ with optional MS20 limit switch

Dimensions in inches

	Dimensions [inches]																
	a	X	b	L	M	c	d	e	f	g	h	p	r	s	t	u	v
Sub-variants: IC/HR IC/TR	12.0	6.5	7.9	12 ... 236	①	4.0 ②	6.5	14.8	4.6	4.6	6 ... 6.7 ③	5.7 ④	4.0 ⑤	3.9 ⑥	Ø2.8 x 0.09	Ø5.1	Ø7.9

- ① this is the measuring range of the indicator column. It is equal to the dimension L.
- ② for IC/HR sub-variant. IC/TR sub-variant: 4.6".
- ③ with optional level transducer
- ④ with optional MS15 limit switch for high-temperature and Ex d applications
- ⑤ with optional MS15 limit switch for low-temperature applications
- ⑥ with optional MS20 limit switch

Weight in kg and lbs

	Weight when L=1000 mm	Weight when L=40 inches	Weight for every additional 100 mm	Weight for every additional 4 inches
	[kg]	[lbs]	[kg]	[lbs]
Bypass chamber	14.5	32.0	0.5	1.1
Level transducer	2.3	5.1	0.1	0.2
MS15 BT limit switch ①	0.13	0.3		
MS15 HT limit switch ②	1.2	2.6		
MS20 limit switch	0.085	0.2		

- ① for low-temperature applications
- ② for high-temperature applications

PTFE-lined sub-variant

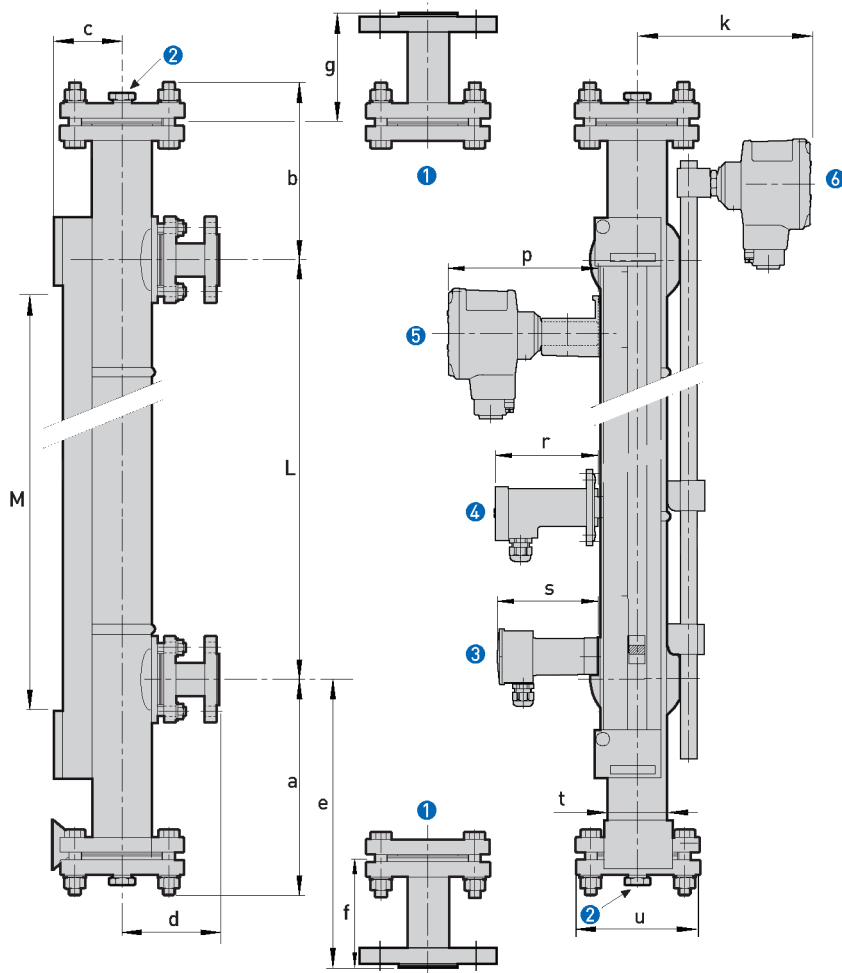

- ① Optional drain or vent with flange connection
- ② Optional drain or vent with NPT $\frac{1}{2}$ plug
- ③ Optional MS20 Std
- ④ Optional MS15 limit switch for low-temperature applications
- ⑤ Optional MS15 limit switch for high-temperature applications
- ⑥ Optional level transducer

Dimensions in mm

	Dimensions [mm]															
	a	X	b	L	M	c	d	e	f	g	k	p	r	s	t	u
Sub-variant: PTFE-lined	300	①	200	300... 6000	②	72	130	375	80	80	189 ③	146 ④	100 ⑤	98 ⑥	Ø80 x 2	Ø16 5

- ① according to process connection size. See the "Process connection dimension X" table at the end of this section.
- ② this is the measuring range of the indicator column. It is equal to the dimension L.
- ③ with optional level transducer
- ④ with optional MS15 limit switch for high-temperature applications
- ⑤ with optional MS15 limit switch for low-temperature applications
- ⑥ with optional MS20 limit switch

Dimensions in inches

	Dimensions [inches]															
	a	X	b	L	M	c	d	e	f	g	k	p	r	s	t	u
Sub-variant: PTFE-lined	12.0	①	7.9	12... 236	②	2.8	5.1	14.8	3.2	3.2	7.5 ③	5.7 ④	4.0 ⑤	3.9 ⑥	Ø3.2 x 0.08	Ø6.5

- ① according to process connection size. See the "Process connection dimension" table at the end of the section.
- ② this is the measuring range of the indicator column. It is equal to the dimension L.
- ③ with optional level transducer
- ④ with optional MS15 limit switch for high-temperature applications
- ⑤ with optional MS15 limit switch for low-temperature applications
- ⑥ with optional MS20 limit switch

Weight in kg and lbs

	Weight when L=1000 mm	Weight when L=40 inches	Weight for every additional 100 mm	Weight for every additional 4 inches
	[kg]	[lbs]	[kg]	[lbs]
Bypass chamber	15.5	34.2	1.2	2.6
Level transducer	2.3	5.1	0.1	0.2
MS15 limit switch BT ①	0.13	0.3		
MS15 limit switch HT ②	1.2	2.6		
MS20 limit switch	0.085	0.2		

- ① for low temperature applications
- ② for high temperature applications

Variant D: two inline process connections

Standard sub-variant

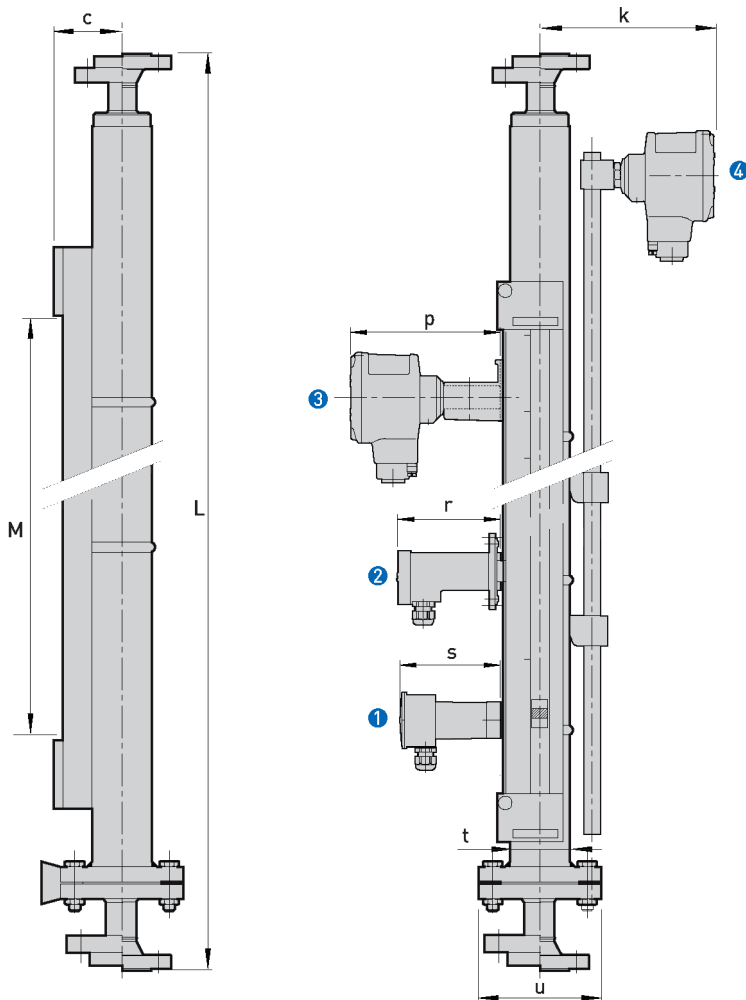

- ① Optional MS20 limit switch
- ② Optional MS15 limit switch for low-temperature applications
- ③ Optional MS15 limit switch for high-temperature and Ex d applications
- ④ Optional level transducer

Note:

- Low-temperature (AG), very low-temperature (IC/TR), high-temperature (HR & IC/HR) and heating/cooling system (B) variants are also available

Dimensions in mm

	Dimensions [mm]								
	c	L	M	k	p	r	s	t	u
Variant: D	72 ①	500...6000	L-480 ②	185 ③	146 ④	100 ⑤	98 ⑥	Ø72 x 2.3	Ø130

- ① 100 mm for low-temperature sub-variant
- ② this is the measuring range of the indicator column
- ③ with optional level transducer
- ④ with optional MS15 limit switch for high-temperature and Ex d applications
- ⑤ with optional MS15 limit switch for low-temperature applications
- ⑥ with optional MS20 limit switch

Dimensions in inches

	Dimensions [inches]								
	c	L	M	k	p	r	s	t	u
Variant: D	2.8 ①	20...236	L-18.9 ②	7.3 ③	5.7 ④	4.0 ⑤	3.9 ⑥	Ø2.8 x 0.09	Ø5.1

- ① 3.9" for low-temperature sub-variant
- ② this is the measuring range of the indicator column
- ③ with optional level transducer
- ④ with optional MS15 limit switch for high-temperature and Ex d applications
- ⑤ with optional MS15 limit switch for low-temperature applications
- ⑥ with optional MS20 limit switch

Weight in kg and lbs

	Weight when L=1000 mm	Weight when L=40 inches	Weight for every additional 100 mm	Weight for every additional 4 inches
	[kg]	[lbs]	[kg]	[lbs]
Bypass chamber	14.5	32.0	0.5	1.1
Level transducer	2.3	5.1	0.1	0.2
MS15 BT limit switch ①	0.13	0.3		
MS15 HT limit switch ②	1.2	2.6		
MS20 limit switch	0.085	0.2		

- ① for low-temperature applications
- ② for high-temperature applications

Variant E: top side and bottom inline process connections

Standard sub-variant

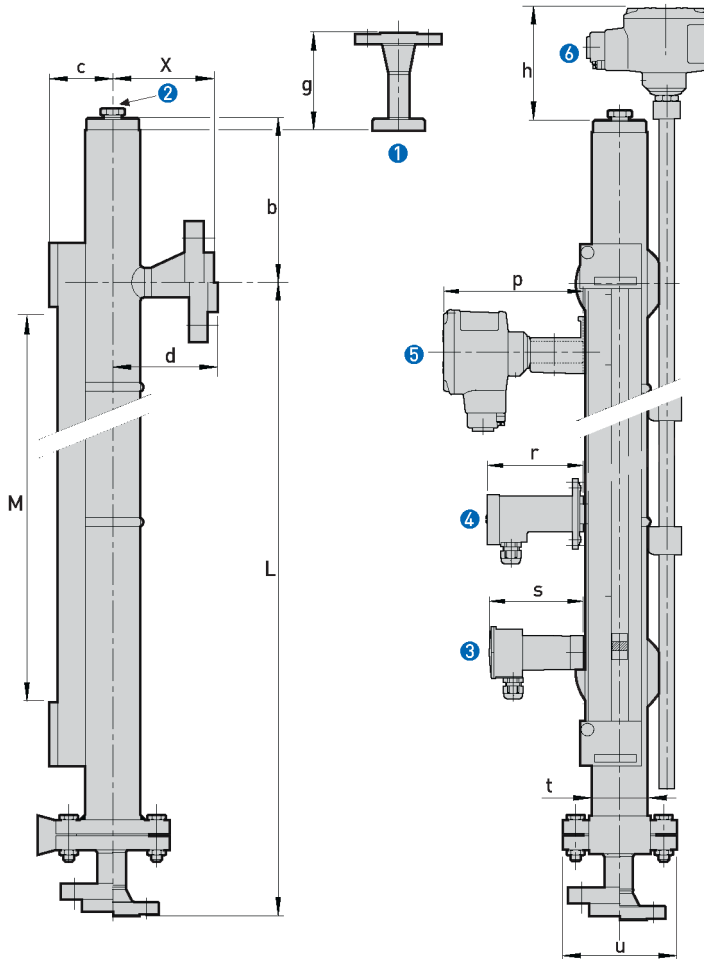

- ① Optional vent with flange connection
- ② Optional vent with G or NPT plug
- ③ Optional MS20 limit switch
- ④ Optional MS15 limit switch for low-temperature applications
- ⑤ Optional MS15 limit switch for high-temperature and Ex d applications
- ⑥ Optional level transducer

Note:

- Low-temperature (AG), very low-temperature (IC/TR), high-temperature (HR & IC/HR) and heating/cooling system (B) variants are also available

Dimensions in mm

	Dimensions [mm]												
	X	b	c	L	M	d	g	h	p	r	s	t	u
Variant: E	①	200	72 ②	500... 6000	L-330 ③	115 ④	116	150... 170 ⑤	146 ⑥	100 ⑦	98 ⑧	Ø72 x 2.3	Ø130

- ① Standard connections: according to process connection size. See the "Process connection dimension X" table at the end of this section.
Long connections: 165 mm
- ② 100 mm for low-temperature sub-variant
- ③ this is the measuring range of the indicator column
- ④ 165 mm for long connections
- ⑤ with optional level transducer
- ⑥ with optional MS15 limit switch for high-temperature and Ex d applications
- ⑦ with optional MS15 limit switch for low-temperature applications
- ⑧ with optional MS20 limit switch

Dimensions in inches

	Dimensions [inches]												
	X	b	c	L	M	d	g	h	p	r	s	t	u
Variant: E	①	7.9	2.8 ②	20... 236	L-13.0 ③	4.5 ④	4.6	6...6.7 ⑤	5.7 ⑥	4.0 ⑦	3.9 ⑧	Ø2.8 x 0.09	Ø5.1

- ① Standard connections: according to process connection size. See the "Process connection dimension X" table at the end of this section.
Long connections: 6.5"
- ② 3.9" for low-temperature sub-variant
- ③ this is the measuring range of the indicator column
- ④ 6.5" for long connections
- ⑤ with optional level transducer
- ⑥ with optional MS15 limit switch for high-temperature and Ex d applications
- ⑦ with optional MS15 limit switch for low-temperature applications
- ⑧ with optional MS20 limit switch

Weight in kg and lbs

	Weight when L=1000 mm	Weight when L=40 inches	Weight for every additional 100 mm	Weight for every additional 4 inches
	[kg]	[lbs]	[kg]	[lbs]
Bypass chamber	14.5	32.0	0.5	1.1
Level transducer	2.3	5.1	0.1	0.2
MS15 BT limit switch ①	0.13	0.3		
MS15 HT limit switch ②	1.2	2.6		
MS20 limit switch	0.085	0.2		

- ① for low-temperature applications
- ② for high-temperature applications

Variant F: top inline and bottom side process connection

Standard sub-variant

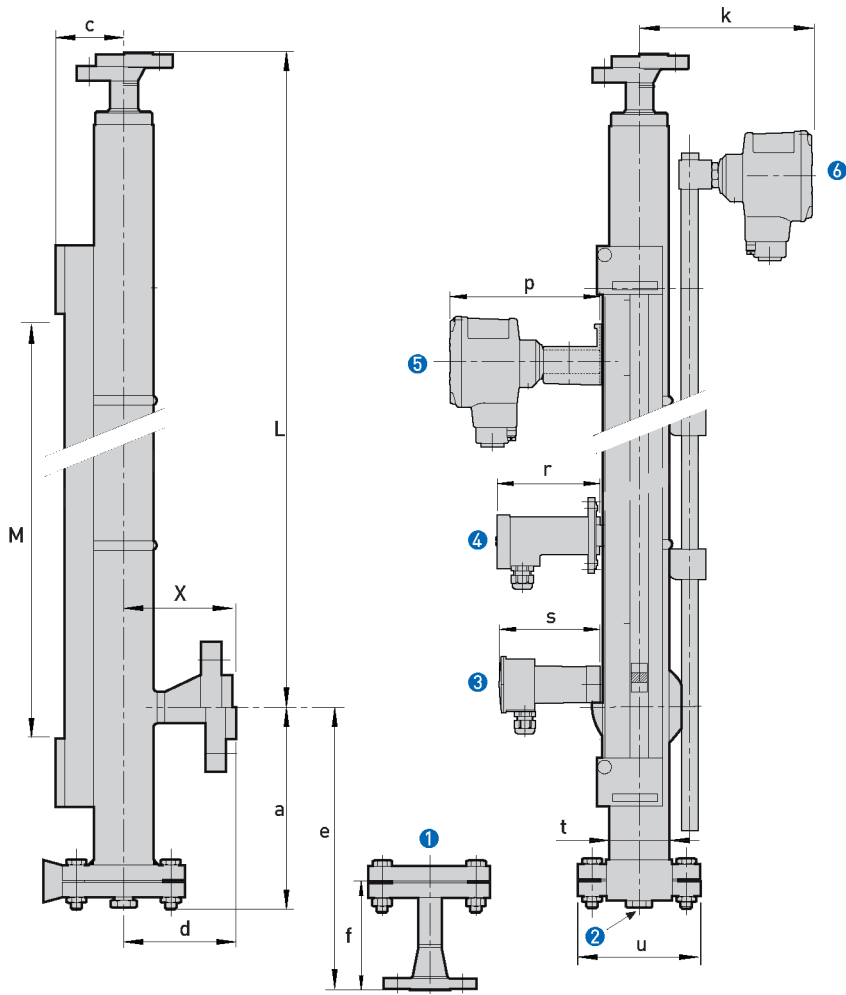

- ① Optional drain with flange connection
- ② Optional drain with G or NPT plug
- ③ Optional MS20 limit switch
- ④ Optional MS15 limit switch for low-temperature applications
- ⑤ Optional MS15 limit switch for high-temperature and Ex d applications
- ⑥ Optional level transducer

Note:

- Low-temperature (AG), very low-temperature (IC/TR), high-temperature (HR & IC/HR) and heating/cooling system (B) variants are also available

Dimensions in mm

	Dimensions [mm]														
	a	X	L	M	c	d	e	f	h	k	p	r	s	t	u
Variant: F	300	①	500 ... 6000	L-200 ②	72 ③	115 ④	375	116	150 ... 170 ⑤	185 ⑤	146 ⑥	100 ⑦	98 ⑧	Ø72 x 2.3	Ø130

- ① Standard connections: according to process connection size. See the "Process connection dimension X" table at the end of this section.
Long connections: 165 mm
- ② this is the measuring range of the indicator column
- ③ 100 mm for low-temperature sub-variant
- ④ 165 mm for long connections
- ⑤ with optional level transducer
- ⑥ with optional MS15 limit switch for high-temperature and Ex d applications
- ⑦ with optional MS15 limit switch for low-temperature applications
- ⑧ with optional MS20 limit switch

Dimensions in inches

	Dimensions [inches]														
	a	X	L	M	c	d	e	f	h	k	p	r	s	t	u
Variant: F	12.0	①	20 ... 236	L-7.9 ②	2.8 ③	4.5 ④	14.8	4.6	6 ... 6.7 ⑤	7.3 ⑤	5.7 ⑥	4.0 ⑦	3.9 ⑧	Ø2.8x 0.09	Ø5.1

- ① Standard connections: according to process connection size. See the "Process connection dimension X" table at the end of this section.
Long connections: 6.5"
- ② this is the measuring range of the indicator column
- ③ 3.9" for low-temperature sub-variant
- ④ Long connections: 6.5"
- ⑤ with optional level transducer
- ⑥ with optional MS15 limit switch for high-temperature and Ex d applications
- ⑦ with optional MS15 limit switch for low-temperature applications
- ⑧ with optional MS20 limit switch

Weight in kg and lbs

	Weight when L=1000 mm	Weight when L=40 inches	Weight for every additional 100 mm	Weight for every additional 4 inches
	[kg]	[lbs]	[kg]	[lbs]
Bypass chamber	14.5	32.0	0.5	1.1
Level transducer	2.3	5.1	0.1	0.2
MS15 BT limit switch ①	0.13	0.3		
MS15 HT limit switch ②	1.2	2.6		
MS20 limit switch	0.085	0.2		

- ① for low-temperature applications
- ② for high-temperature applications

Tables for process connection dimension X

Process connection length, X, in mm (EN welding neck flanges)

Nominal size	Pressure rating	Process connection length, X
DN	PN	[mm]
15	40	79.5
20	40	81.5
25	40	81.5
40	40	86.5
50	40	89.5

Process connection length, X, in inches (EN welding neck flanges)

Nominal size	Pressure rating	Process connection length, X
DN	PN	[inches]
15	40	3.13
20	40	3.21
25	40	3.21
40	40	3.41
50	40	3.52

Process connection length, X, in mm (ASME welding neck flanges flanges)

Nominal size	Pressure rating	Process connection length, X
ASME		[mm]
½"	150LB	89.5
¾"	150LB	93.5
1"	150LB	97.5
1½"	150LB	103.5
2"	150LB	104.5
½"	300LB	93.5
¾"	300LB	98.5
1"	300LB	103.5
1½"	300LB	109.5
2"	300LB	111.5

Process connection length, X, in inches (ASME welding neck flanges flanges)

Nominal size	Pressure rating	Process connection length, X
ASME		[inches]
½"	150LB	3.52
¾"	150LB	3.84
1"	150LB	4.07
1½"	150LB	4.11
2"	150LB	3.68
½"	300LB	3.68
¾"	300LB	3.88
1"	300LB	4.07
1½"	300LB	4.31
2"	300LB	4.39

Guidelines for maximum operating pressure

Note:

Ensure that meters are used within their operating limits. Observe the following requirements.

**Flanged connections for BM 26 chamber according to EN 1092-1:
Pressure / temperature de-rating for 316 L (1.4404) stainless steel meters**

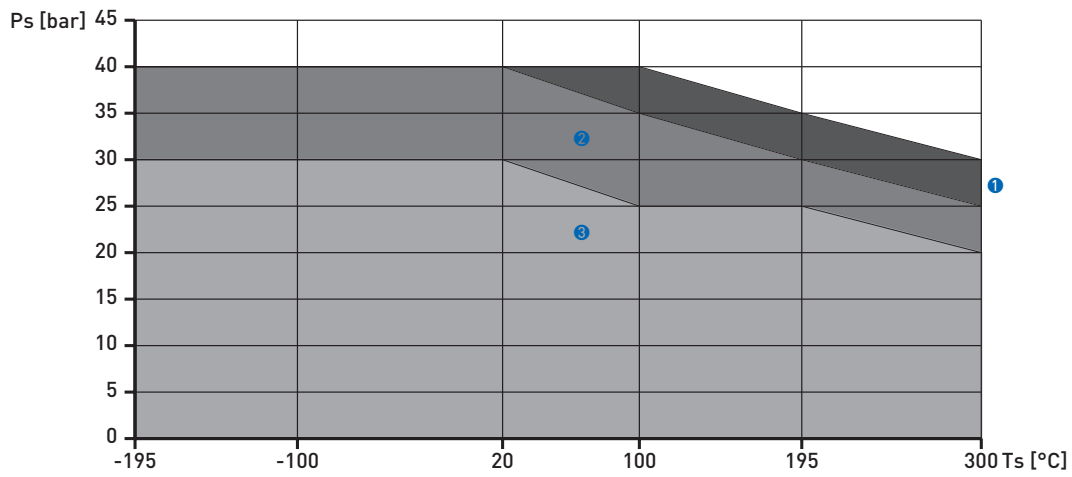

- ① Loose and Welding Neck PN40 flanges for sizes DN15 and DN20
- ② Loose and Welding Neck PN40 flange for size DN25
- ③ Loose and Welding Neck PN40 flanges for sizes DN40 and DN50

Pressure / temperature de-rating for 316 Ti (1.4571) stainless steel meters

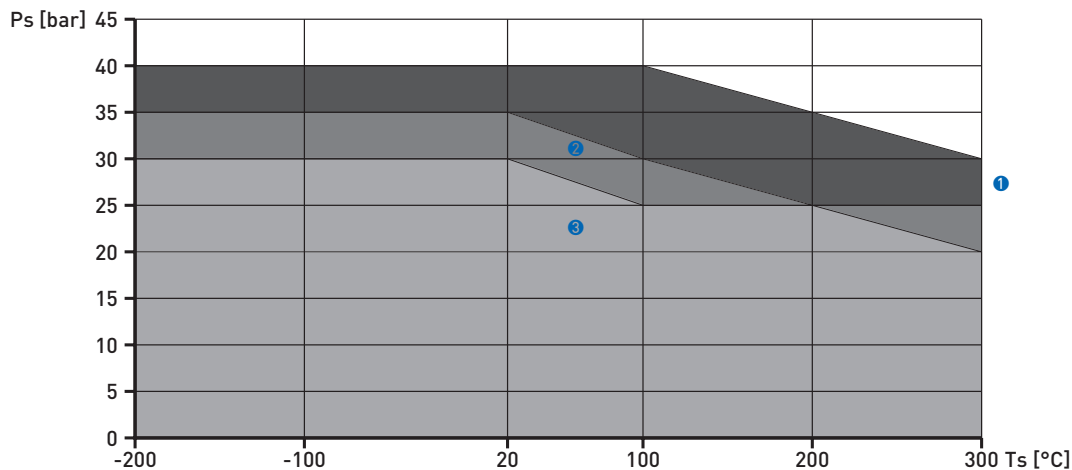

- ① Loose and Welding Neck PN40 flanges for sizes DN15, DN20, and DN25
- ② Loose and Welding Neck PN40 flange for size DN50
- ③ Loose and Welding Neck PN40 flanges for sizes DN40

Flanged connections for BM 26 chamber according to ASME:
 Pressure / temperature de-rating for 316 L (1.4404) stainless steel meters

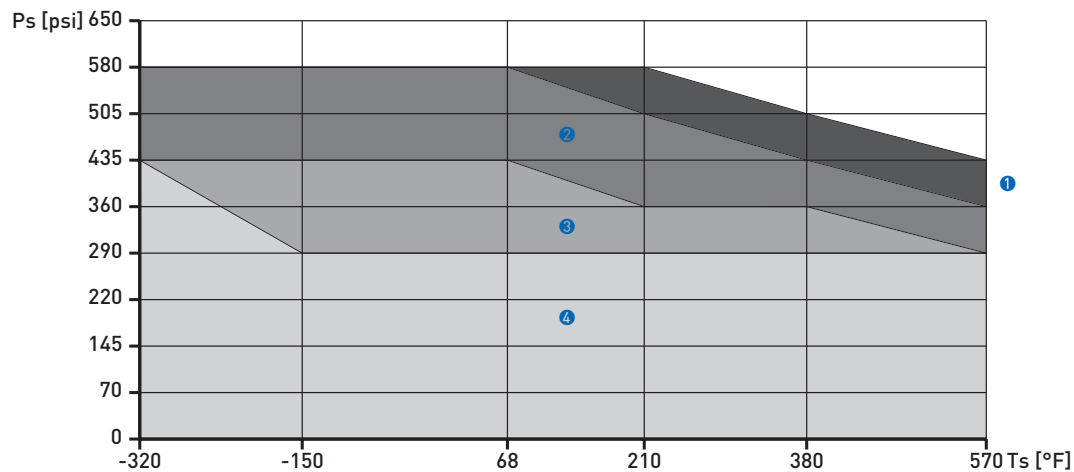

- ① ASME 300 lb flanges for sizes ½" and ¾"
- ② ASME 300 lb flange for size 1"
- ③ ASME 300 lb flanges for sizes 1½" and 2"
- ④ ASME 150 lb flanges for sizes ½", ¾", 1", 1½", and 2"

Pressure / temperature de-rating for 316 Ti (1.4571) stainless steel meters

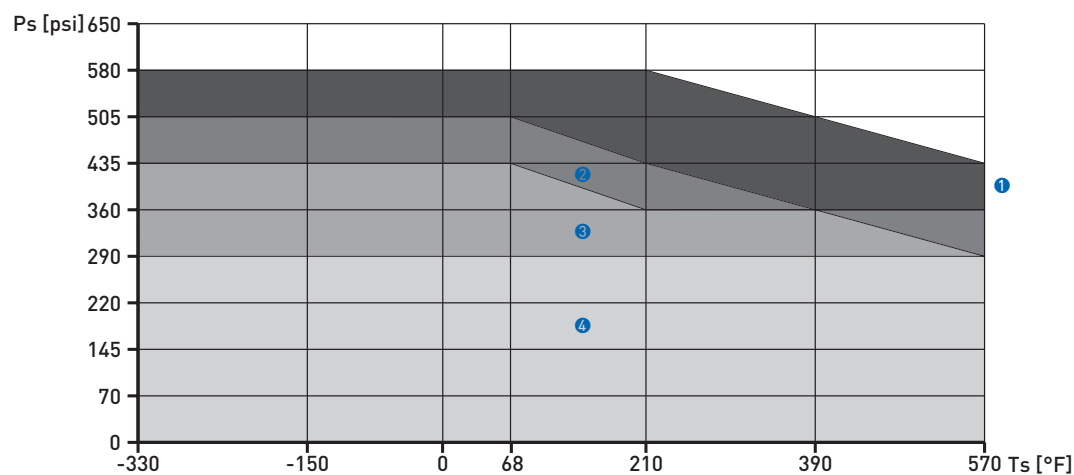

- ① ASME 300 lb flanges for sizes ½", ¾", 1", and 1½"
- ② ASME 300 lb flange for size 2"
- ③ No ASME flanges covered by this category
- ④ ASME 150 lb flanges for sizes ½", ¾", 1", 1½", and 2"

Flanged connections for BM 26 chamber according to EN 1092-1:
 Pressure / temperature de-rating for PTFE-lined 316 L (1.4404) stainless steel meters

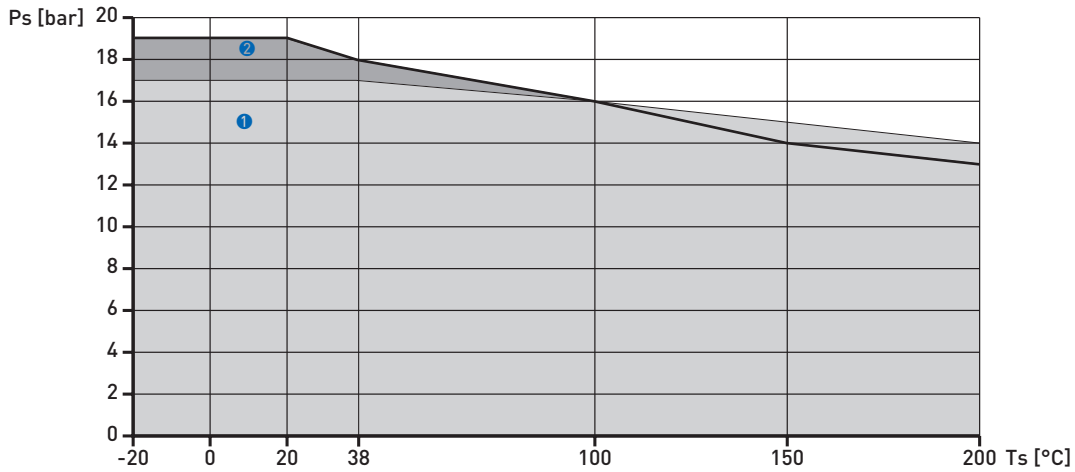

- ① PN10/16 flanges for sizes DN25, DN40, and DN50
- ② No PN flanges covered by this category

Flanged connections for BM 26 chamber according to ASME:
 Pressure / temperature de-rating for PTFE-lined 316 L (1.4404) stainless steel meters

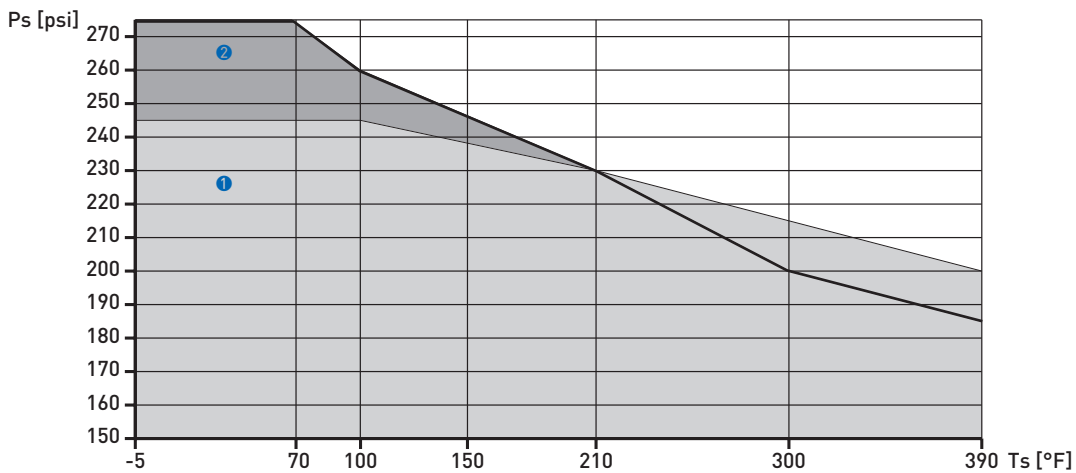

- ① No ASME flanges covered by this category
- ② ASME 150 lb flanges for sizes 1", 1½", and 2"

Pressure de-rating for heating/cooling system (sub-variant B)

Where L is the height of the bypass chamber between process connection axes

Maximum pressure of heating/cooling system in bar (for a given bypass chamber length)

	L	Pmax.
	m	bar
Sub-variant B: heating/cooling system	0...2	10
	2...4	7
	4...6	5

Maximum pressure of heating/cooling system in psig (for a given bypass chamber length)

	L	Pmax.
	ft.	psig
Sub-variant B: heating/cooling system	0...6.5	145
	6.5...13	101.5
	13...19.5	72.5

KROHNE Product Overview

- Electromagnetic flowmeters
- Variable area flowmeters
- Mass flowmeters
- Ultrasonic flowmeters
- Vortex flowmeters
- Flow controllers
- Level measuring instruments
- Pressure gauges
- Temperature measuring instruments
- Water solutions & analysis
- Oil and gas turnkey solutions

Addresses:

Germany

Northern sales office

KROHNE Messtechnik GmbH & Co. KG
Bremer Str. 133
D-21073 Hamburg
Phone: +49 (0)40 767 3340
Fax: +49 (0)40 767 33412
nord@krohne.de
ZIP code: 10000 - 29999, 49000 - 49999

Western and middle sales office

KROHNE Messtechnik GmbH & Co. KG
Ludwig-Krohne-Straße
D-47058 Duisburg
Phone: +49 (0)203 301 416
Fax: +49 (0)203 301 10416
west@krohne.de
ZIP code: 30000 - 34999, 37000 - 48000, 50000 - 53999, 57000 - 59999, 98000 - 99999

Southern sales office

KROHNE Messtechnik GmbH & Co. KG
Landsberger Str. 392
D-81241 Munich
Phone: +49 (0)89 121 5620
Fax: +49 (0)89 129 6190
sued@krohne.de
ZIP code: 0 - 9999, 80000 - 89999, 90000 - 97999

Southwestern sales office

KROHNE Messtechnik GmbH & Co. KG
Rüdesheimer Str. 40
D-65239 Hochheim/Main
Phone: +49 (0)6146 827 30
Fax: +49 (0)6146 827 312
rhein-main@krohne.de
ZIP code: 35000 - 36999, 54000 - 56999, 60000 - 79999

Instrumentation and control equipment catalog

TABLAR Messtechnik GmbH
Ludwig-Krohne-Straße 5
D-47058 Duisburg
Phone: +49 (0)2 03 305 880
Fax: +49 (0)2 03 305 8888
kontakt@tablar.de www.tablar.de

KROHNE sales companies

International

Australia

KROHNE Australia Pty Ltd
Quantum Business Park 10/287
Victoria Rd Rydalmere NSW 2116
Phone: +61 2 8846 1700
Fax: +61 2 8846 1755
krohne@krohne.com.au

Austria

KROHNE Gesellschaft m.b.H.
Modecenterstraße 14
A-1030 Vienna
Phone: +43 (0)1/203 45 32
Fax: +43 (0)1/203 45 32 99
info@krohne.at

Belgium

KROHNE Belgium N.V.
Brusselstraat 320
B-1702 Groot Bijgaarden
Phone: +32 (0)2 4 66 00 10
Fax: +32 (0)2 4 66 08 00
krohne@krohne.be

Brazil

KROHNE Conaut Controles Automáticos Ltda.
Estrada Das Águas Espraiadas, 230
C.P. 56 06835 - 080 EMBU - SP
Phone: +55 (0)11-4785-2700
Fax: +55 (0)11 4785-2768
conaut@conaut.com.br

China

KROHNE Measurement Instruments (Shanghai) Co. Ltd., [KMIC]
Room 1501
1033 Zhaojabang Road
Shanghai 200030
Phone: +86 21 6487 9611
Fax: +86 21 6438 7110
info@krohne-asia.com

Czech Republic

Krohne CZ, spol. s r.o.
Sobisická 156
63800 Brno
Phone: +420 (0)545.242 627
Fax: +420 (0)545 220 093
brno@krohne.cz

France

KROHNE S.A.S.
Les Ors BP 98
F-26103 ROMANS Cedex
Phone: +33 (0)4 75 05 44 00
Fax: +33 (0)4 75 05 00 48
info@krohne.fr

Great Britain

KROHNE Ltd.
Rutherford Drive
Park Farm Industrial Estate
Wellingborough
Northants NN8 6AE
Phone: +44 (0)19 33 408 500
Fax: +44 (0)19 33 408 501
info@krohne.co.uk

CIS

Kanex KROHNE Engineering AG
Business-Centre Planeta
Office 404 ul.
Marxistskaja 3
109147 Moscow/Russia
Phone: +7 (0)095 911 7165
Fax: +7 (0)095 742 8873
krohne@dol.ru

India

Krohne Marshall Ltd.
A-34/35, M.I.D.C. Industrial Area,
H-Block
Pimpri Poona 411018
Phone: +91 (0)202 744 2020
Fax: +91 (0)202 744 2020
pcui@vsnl.net

Iran

KROHNE Liaison Office
North Sohrvardi Ave. 26,
Sarmad St., Apt. #9
Tehran 15539
Phone: +9821 8874 5973
Fax: +9821 8850 1268
krohne@krohneiran.com

Italy

KROHNE Italia Srl.
Via V. Monti 75
I-20145 Milan
Phone: +39 02 4300 661
Fax: +39 02 4300 6666
info@krohne.it

Korea

KROHNE Korea
Room 508 Miwon Bldg 43
Yoido-Dong Youngdeungpo-Ku
Seoul, Korea
Phone: 00-82-2-782-1900
Fax: 00-82-2-780-1749
mail@krohne.co.kr

Netherlands

KROHNE Nederland B.V.
Kerkepleat 14
NL-3313 LC Dordrecht
Phone: +31 (0)78 630 6200
Fax: +31 (0)78 630 6405
Service Direct: +31 (0)78 630 6222
info@krohne.nl

Norway

KROHNE Norway A.S.
Ekholtveien 114
NO-1521 Moss
Phone: +47 (0)69 264 860
Fax: +47 (0)69 267 333
postmaster@krohne.no

Poland

KROHNE Polska Sp.z.o.o.
ul. Stary Rynek Oliwski 8a
80-324 Gdansk
Phone: +48 (0)58 520 9211
Fax: +48 (0)58 520 9212
info@krohne.pl

Switzerland

KROHNE AG
Uferstr. 90
CH-4019 Basel
Phone: +41 (0)61 638 30 30
Fax: +41 (0)61 638 30 40
info@krohne.ch

Singapore

Tkto Keiso - KROHNE (Singapore) Pte. Ltd.
14, International Business Park,
Jurong East
Chiyoda Building, #01-01/02
Singapore 609922
Phone: (65) 6567 4548
Fax: (65) 6567 9874
tks@tokyokeiso-krohne.com.sg

Republic of South Africa

KROHNE Pty. Ltd.
Bushbuck Close
Corporate Park South
Midrand, Gauteng
P.O. Box 2069
Midrand, 1685
Tel.: +27 (0)11 314 1391
Fax: +27 (0)11 314 1681
midrand@krohne.co.za

Spain

I.I. KROHNE IBERIA, S.r.l.
Polígono Industrial Nilo
Calle Brasil, nº. 5
28806 Alcalá de Henares Madrid
Phone: +34 (0)91 883 2152
Fax: +34 (0)91 883 4854
krohne@krohne.es

USA

KROHNE, Inc.
7 Dearborn Road
Peabody, MA 01960
Phone: +1 (800) FLOWING
Phone: +1 (978) 535 6060 (in MA)
info@krohne.com

Representatives

Algeria
Argentina
Cameroon
Canada
Chile
Columbia
Croatia
Denmark
Ecuador
Egypt
Finland
Gabon
Ghana
Greece
Hong Kong
Hungary
Indonesia
Iran
Ireland
Israel
Ivory Coast
Japan
Jordan
Kuwait
Libya
Lithuania
Malaysia
Mauritius
Mexico
Morocco
New Zealand
Peru
Portugal
Romania
Saudi Arabia
Senegal
Slovakia
Slovenia
Sweden
Taiwan
Thailand
Tunisia
Turkey
Venezuela
Yugoslavia

Other countries

KROHNE Messtechnik GmbH & Co. KG
Ludwig-Krohne-Str. 5
D-47058 Duisburg
Phone: +49 (0)203 301 0
Fax: +49 (0)203 301 389
export@krohne.de