

## **D2000M SERIES**

Intrinsically Safe Modular

## **Multiplexer System**

for Installation in Hazardous

## **Areas Zone 0, 1, 2**

Gas Group IIC, IIB, IIA T4

Class I, II, III, Div. 1, Groups A,

B, C, Indoor and Outdoor

Hazardous Locations



Transmit up to 7936 Analog, or 3968 Digital, Signals from TC, RTD, mV, 4-20 mA, or contact, Proximity sensors, at distances up to 5 Kilometers.

# D2000M Series Intrinsically Safe Modular Multiplexer System

## System Features

- High Density, up to 256 Analog Inputs (TC, RTD, mV, mA, Ohm) and up to 128 Digital inputs (Contacts, Proximity sensors) on the same system.

Expandable up to 7936 Analog and 3968 Digital.

- Robust Galvanic Isolation ( $\pm 200$  V channel to channel) provides high immunity against interferences and ground loops.
- Intrinsically Safe for installation in Zone 0, 1, 2, 20, 21, 22, Gas Group IIC T4 or Class I, II and III, Division 1 and Class I, Zone 0 & 1 Hazardous Location.
- Send data as far as 5 Km distance at high speed 38400 baud.
- High Accuracy 18 bits D/D converter.
- Direct connection of sensors to input plug-in type Terminal Blocks. No auxiliary Terminal Blocks required.
- Communication line, used also as Supply line, can be redundant.
- IEC Ex, ATEX, FM, FM-C, GOST Certifications.
- System configuration software performed [SW free of charge].

- Interfaces with PLC/DCS via redundant Modbus RTU protocol.
- Connects directly to PC RS 232 port for system configuration and diagnostic.

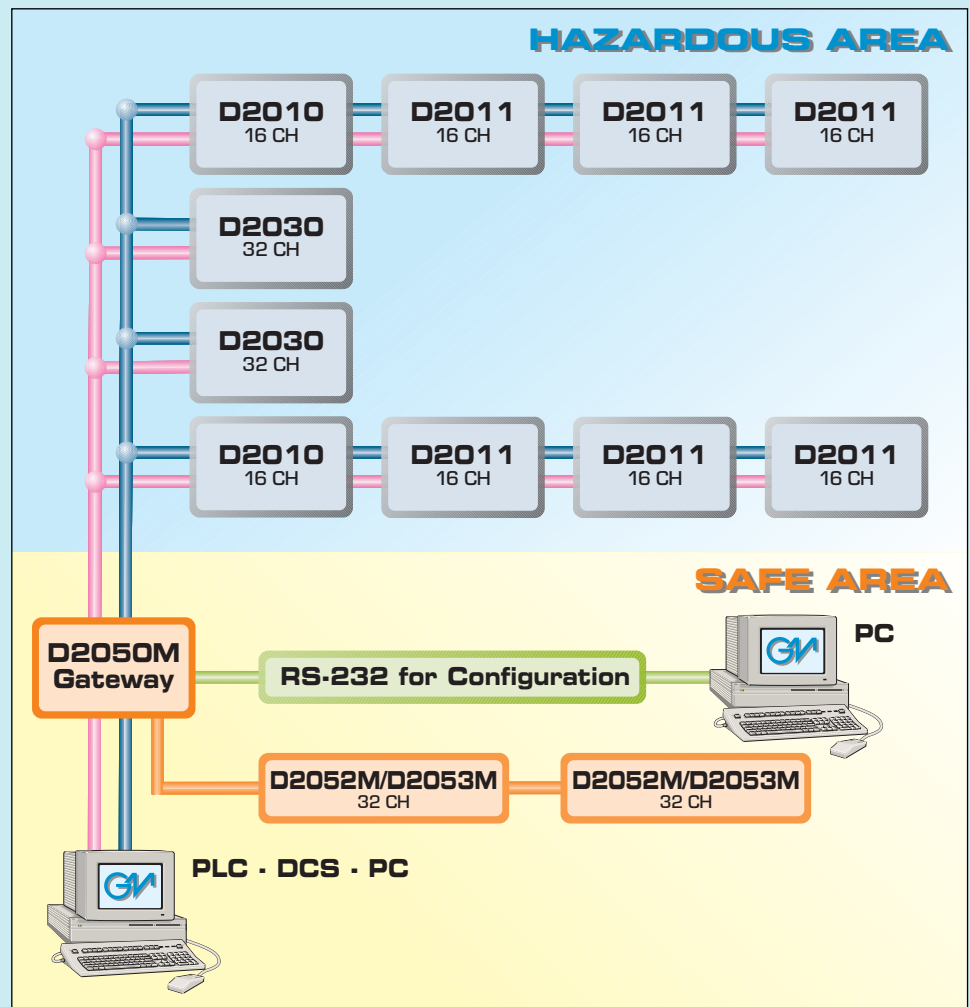

- Repeats input contact via Relays or O.C. Transistor Outputs.
- Lower Cables and installation costs.
- Lower PLC-DCS I/O card costs.
- Lower wiring costs, 1 terminal Block per input connection, no auxiliary T.B. needed.
- Simplified Installation.

# Brief Information about Multiplexing Technique

## Signal Data Acquisition

In industrial process is a common need to acquire a relevant number of temperatures, pressures, flows, levels and other process variables as well as the status of switches or proximity sensors and collect all these data in a single remote collection area (i.e. in a control room) where a PLC (Programmable Logic Controller) or a Process Computer collect all data and use them for monitoring purposes or make them available to the operators.

SCADA (Signal Conditioning And Data Acquisition) equipment are particularly suited for this purpose.

Modern micro electronics permits fast, accurate and stable Analog to Digital converters, high speed computing, sophisticated intelligence and powerful measuring capabilities.

All this performance can be packed into compact reliable units that can operate in harsh environments.

Multiplexers are a typical SCADA multi channel equipment that can be located in the field close to the process area where the input channels can be connected with short lines. All input channel signals are converted in a numeric form and transmitted to a remote location via a single communication line.

## How a Multiplexer works

The multiplexer cyclically scans each input channel for a few milliseconds (connects with electrical or semiconductor switches each input signal, one at a time, to the internal circuits) and converts with an A/D (Analog to Digital) converter each process signal into a digital value.

This digital value is computed by a microprocessor and transformed into a numerical data expressed in terms of engineering units corresponding to the effective process variable of the channel (°C, PSI or ATE, liters/sec etc). After completion of the scanning and conversion cycle of one channel the multiplexer connects the next channel in a sequential fashion so that in a few milliseconds all input

channel signals are converted into their corresponding numerical data, expressed in engineering units and stored on a buffer memory.

Multiplexers also perform the tagging of each variable for channel identification and diagnostic functions to detect failures, out of range values, errors in the data etc.; all data are transmitted under command in a numerical form as a sequence of strings via a single serial communication interface and connection line up to the data collection area (i.e. in a control room).

Communication line can also serve as supply line eliminating the need of an extra power line. Additionally, the supply/communication line can be dual redundant to eliminate the effects of failures in one of the lines.

## When multiplexing is the only viable solution

In the case of revamping or add-on of new parts in the plant, the space for adding cables may be limited or the few existing spare cables are the only ones that can be used.

Radio Frequency links, beside cost and licensing problems, present severe data security and reliability limitations that make, most of the times, this technique impractical. Multiplexer becomes the only practical solution.

## The advantages of multiplexing

When a consistent quantity of variables must be made available to a far location, instead of wiring each process variable signal with long individual connection lines up to the control room, it is advantageous to connect all input signals to a conveniently field located Multiplexer with short local connections lines to the sensors and to send all data through a single communication line to the remote data collection area. Even when space for cable is available the saving just in cable cost alone justifies, most of the times, the multiplexer solution, in addition a tidy simple connection is obtained avoiding cluttering of wires in the control room area.

## Multiplexing in Hazardous area

For applications in classified hazardous areas each signal must be protected from the risk of causing an ignition of flammable mixtures, this requires a safety barrier for each input channel and a protection for the multiplexer itself and its communication line substantially increasing the complexity and cost of such a solution.

### The advantages of using an Intrinsically Safe Multiplexer

The use of an intrinsically safe multiplexer allows equipment installation in hazardous area and connection of all its inputs directly to the process variable signals without the requirement of any further protection; retaining the simplicity and cost effectiveness of a multiplexing solution.

In addition to the cable cost and simplicity of installation discussed above, the elimination of safety barriers drastically simplifies and reduces the cost of this solution compared to other options.

## D2000M Series General Description

D2000M Series Intrinsically Safe Multiplexing System consists of one to four Analog-Temperature Multiplexer Units model D2010M, up to twelve Expander Units model D2011M, or up to four D2030M Digital Multiplexer Units, mounted in Zone 0, 1, 2 Hazardous Area, Gas Group IIC T4, connected via a single / redundant 2 wire data communication / Supply line to a Modbus Gateway Unit model D2050M, mounted in Safe Area and connected to a PLC, DCS or PC.

The Multiplexer Units D2010M, and the Expander Units D2011M can be installed in the field, close to input sensors, for data acquisition from Hazardous Areas and connected to a Safe Area PLC/DCS or other devices, via 2 wire communication link and the Gateway Unit D2050M, saving wiring, cables and costs.

The Units are primarily intended for Hazardous Areas acquisition of low level signal from Thermocouples, RTDs, mV or mA sources.

The Expander Units D2011M are controlled by D2010M Units. D2010M scans all enabled channels using state



### D2050M Gateway Unit.

of the art solid state isolated relays, and stores all data in a memory buffer, where they can be rapidly accessed by the Modbus Gateway Unit D2050M.

Each Mux Unit accepts directly up to 16 input channels and, by adding from one to three Expander Units D2011M, is expandable to 64 channels in blocks of 16



### D2010M Multiplexer Unit.

each. Four D2010M Units, connected to twelve D2011M Expanders reach 256 inputs with a single Modbus Gateway Unit D2050M. Redundant communication is obtained by in built dual data/supply interface line. Safety Parameters maintain capability with Gas Group IIC (A, B) even in redundant mode.

An Integrating type, High Rejection, High Accuracy (18 bits) A/D Converter, automatically calibrates Zero and Span providing accurate and stable measurements. All parameters are software configurable by serial commands via the D2050M Unit.

The Multiplexer Units D2030M, can be installed in the field close to input sensors, for data acquisition from Hazardous Areas and connected to a Safe Area PLC/DCS or other devices, via 2 wire communication link and Gateway Unit D2050M, saving wiring, cables and costs.

These Units are primarily intended for Hazardous Area acquisition from contacts or proximity detectors. D2030M scans all enabled channels and stores all data in a memory buffer, where they can be rapidly accessed by the Modbus Gateway Unit D2050M.

Each Mux Units D2030M accepts directly up to 32 inputs channels and from one to four Units can be used in a System.

Four D2030M Units reach 128 inputs with a single Modbus Gateway Unit D2050M.

Redundant communication is obtained by in built dual

data/supply interface line.

Safety Parameters maintain compatibility with Gas Group IIC (A, B) even in redundant mode.

The D2052M Unit is equipped with 32 relay output SPDT contacts. Connected to D2050M Unit it repeats the status of each D2030M digital input Multiplexer Unit.

The D2053M Unit is equipped with 32 Open Collector Transistor Outputs. Connected to D2050M Unit it repeats the status of each D2030M digital input Multiplexer Unit.

Distance between Gateway Unit D2050M and the field Units D2010M, D2011M, D2030M can be up to 1000 mt. for gas group IIC (A, B) and up to 5000 mt. for group IIB, IIA (C, D, E, F, G).

GM CABF008 is an available cable for communication lines between the D2050M Gateway and field Units.

**NOTE:** This cable is included in the system certification and it may be substituted only by cables with same specifications, in order for the certification to maintain its validity.

# ANALOG - TEMPERATURE MULTIPLEXER D2000M SERIES SYSTEM SUITABLE for INSTALLATION in ZONE 0, 1, 2 CONFIGURATION for 64 TEMPERATURE INPUTS

## HAZARDOUS AREA

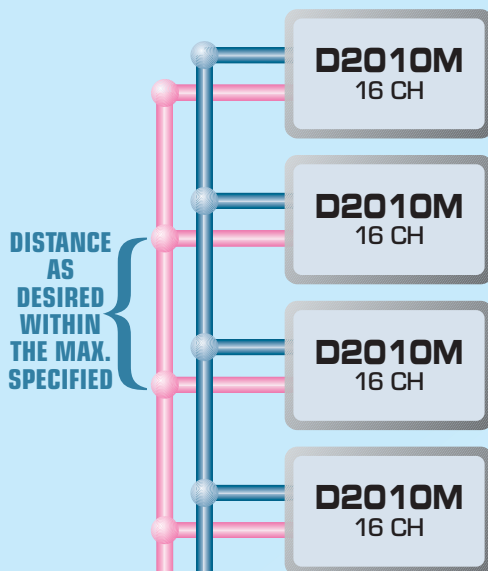

160 CHANNEL PER SECOND  
MAXIMUM SCANNING TIME FOR  
ALL CHANNELS: 400 mSec

MAXIMUM DISTANCE BETWEEN  
D2050M and D2010M, using GM  
Type CABF008 cable, is 1 Km  
for GAS GROUP IIC and up to 5 Km  
for IIB depending on configuration  
(nr. of channels, nr. of units and their  
distances).

## SAFE AREA

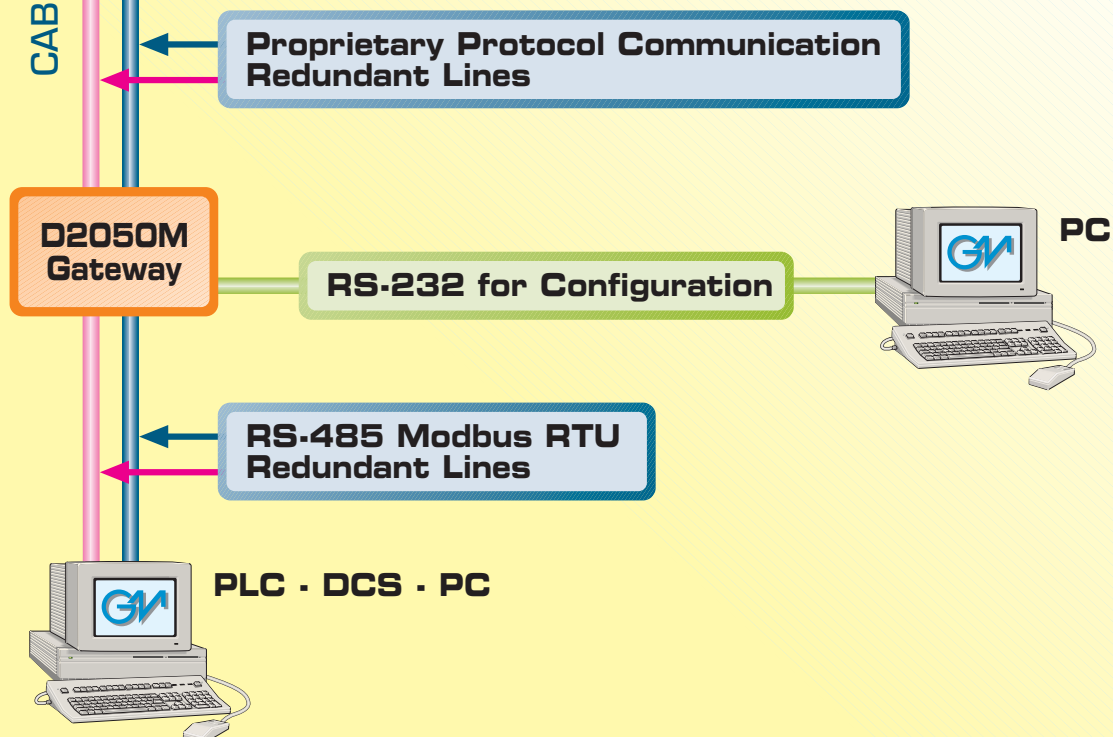

**ANALOG - TEMPERATURE MULTIPLEXER D2000M SERIES SYSTEM SUITABLE for INSTALLATION in ZONE 0, 1, 2 CONFIGURATION for 256 TEMPERATURE INPUTS**

**HAZARDOUS AREA**

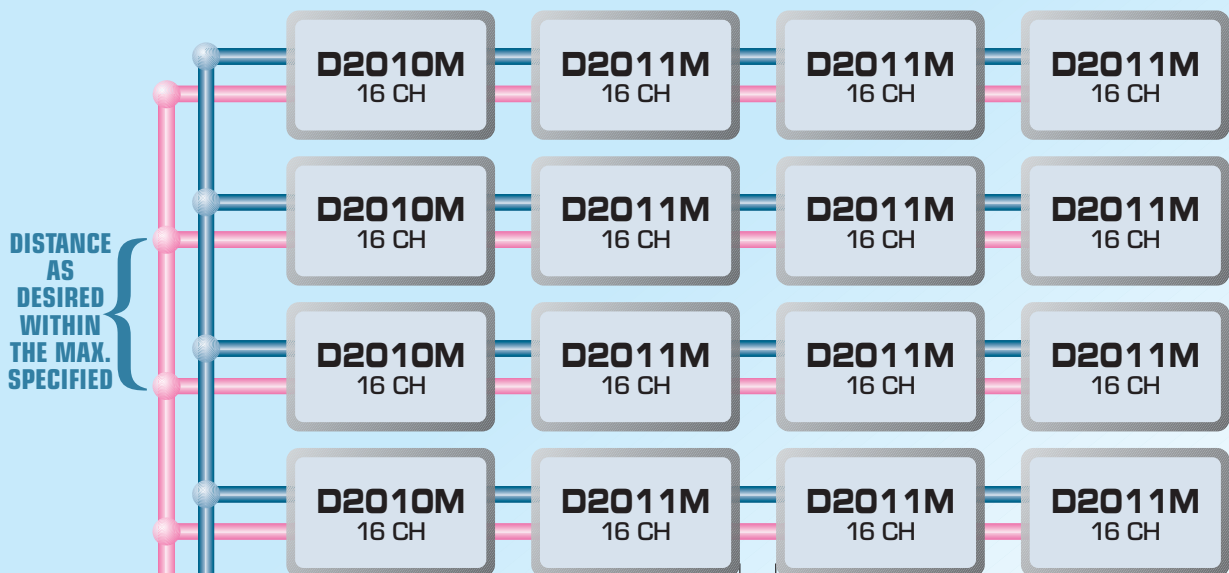

CABLE DISTANCE: 150-300 mm

160 CHANNEL PER SECOND MAXIMUM SCANNING TIME FOR ALL CHANNELS: 1,6 msec.  
 MAXIMUM DISTANCE BETWEEN D2050M and D2010M, using GM Type CABFO08 cable, is 1 Km for GAS GROUP IIC and up to 5 Km for IIB depending on configuration (nr. of channels, nr. of units and their distances).

**SAFE AREA**

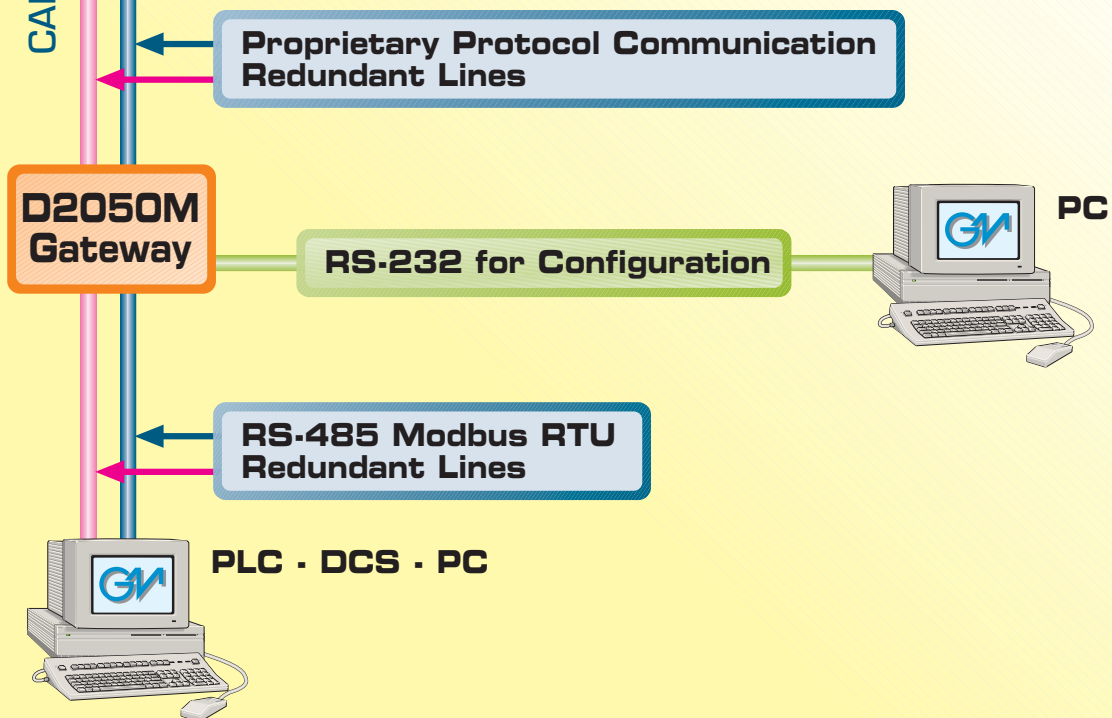

**ANALOG - TEMPERATURE - DIGITAL MULTIPLEXER D2000M SERIES**  
**SYSTEM SUITABLE for INSTALLATION in ZONE 0, 1, 2**  
**CONFIGURATION for 192 TEMPERATURE and 32 DIGITAL INPUTS**

**HAZARDOUS AREA**

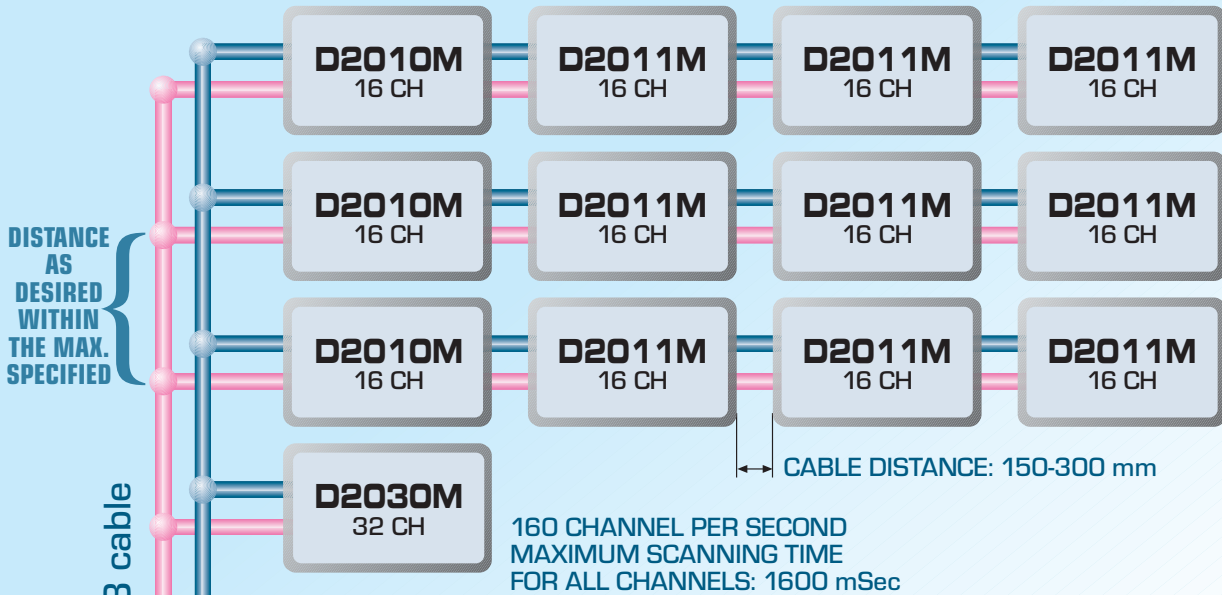

MAXIMUM DISTANCE BETWEEN D2050M and D2010M, using GM Type CABFO08 cable, is 1 Km for GAS GROUP IIC and up to 5 Km for IIB depending on configuration (nr. of channels, nr. of units and their distances).

**SAFE AREA**

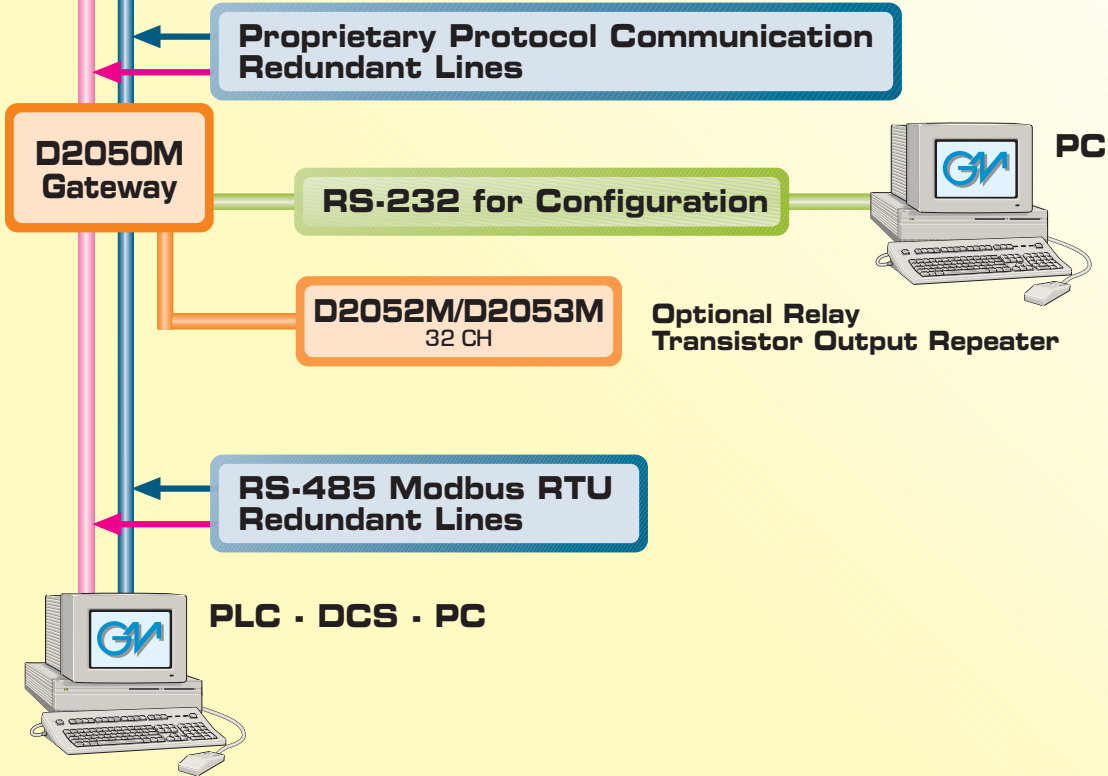

**MULTIPLEXER D2000M SERIES SYSTEM SUITABLE for INSTALLATION in ZONE 0, 1, 2 MAX. CONFIGURATION for 128 DIGITAL INPUTS and 128 REPEATER OUTPUTS**

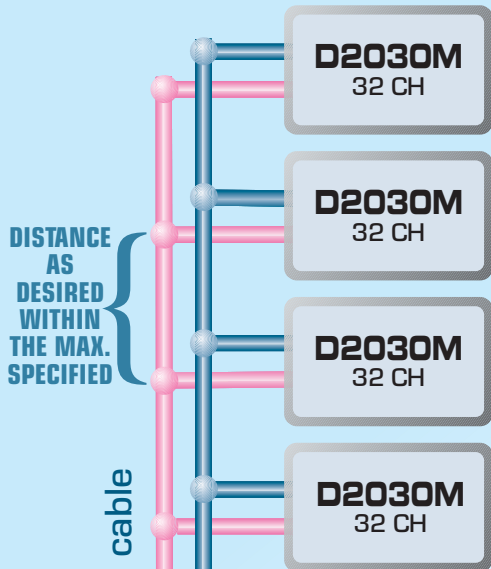

**HAZARDOUS AREA**

MAXIMUM SCANNING TIME FOR ALL CHANNELS: 50 mSec

MAXIMUM DISTANCE BETWEEN D2050M and D2010M, using GM Type CABF008 cable, is 1 Km for GAS GROUP IIC and up to 5 Km for IIB depending on configuration (nr. of channels, nr. of units and their distances).

**SAFE AREA**

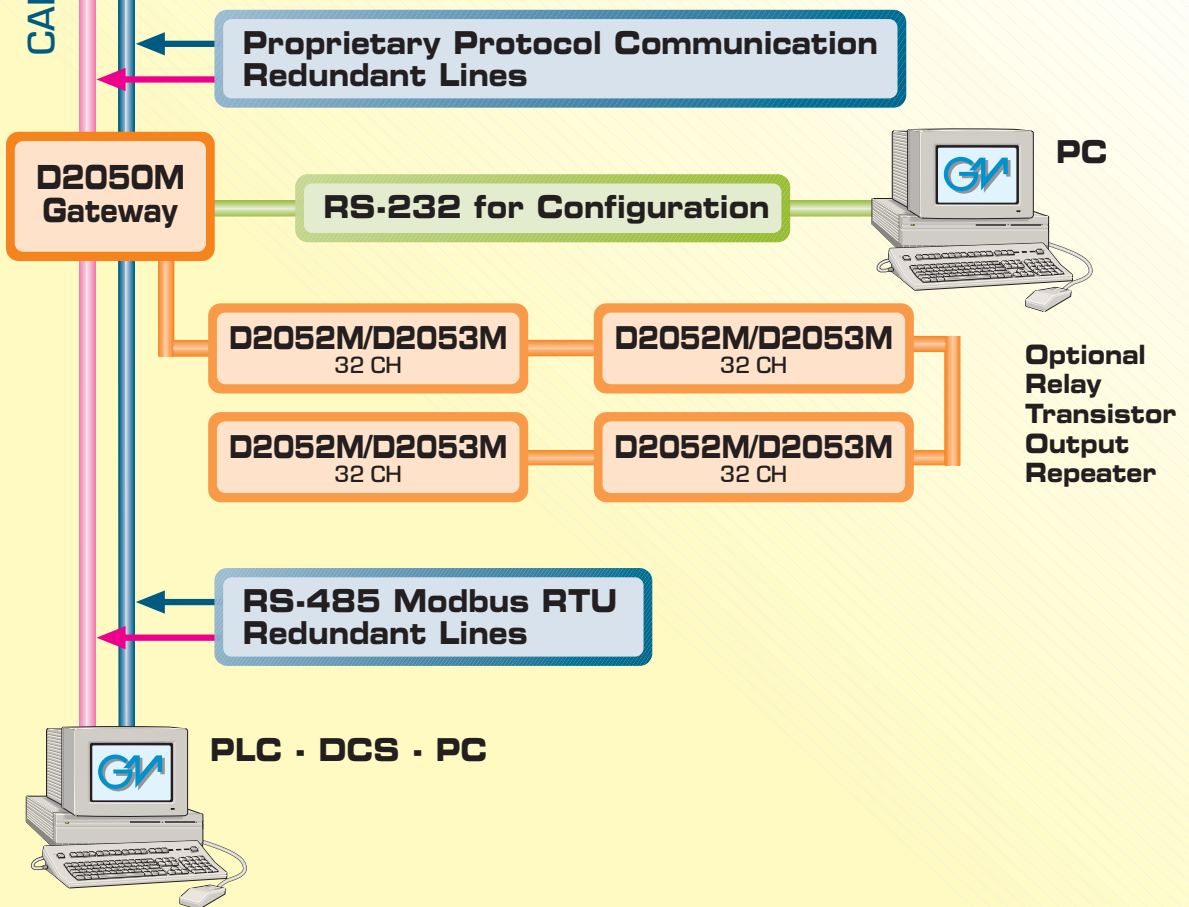

**ANALOG - TEMPERATURE - DIGITAL MULTIPLEXER D2000 SERIES**  
**SYSTEM SUITABLE for INSTALLATION in ZONE 0, 1, 2**  
**CONFIGURATION for 128 TEMPERATURE INPUTS and 64 DIGITAL INPUTS**

**HAZARDOUS AREA**

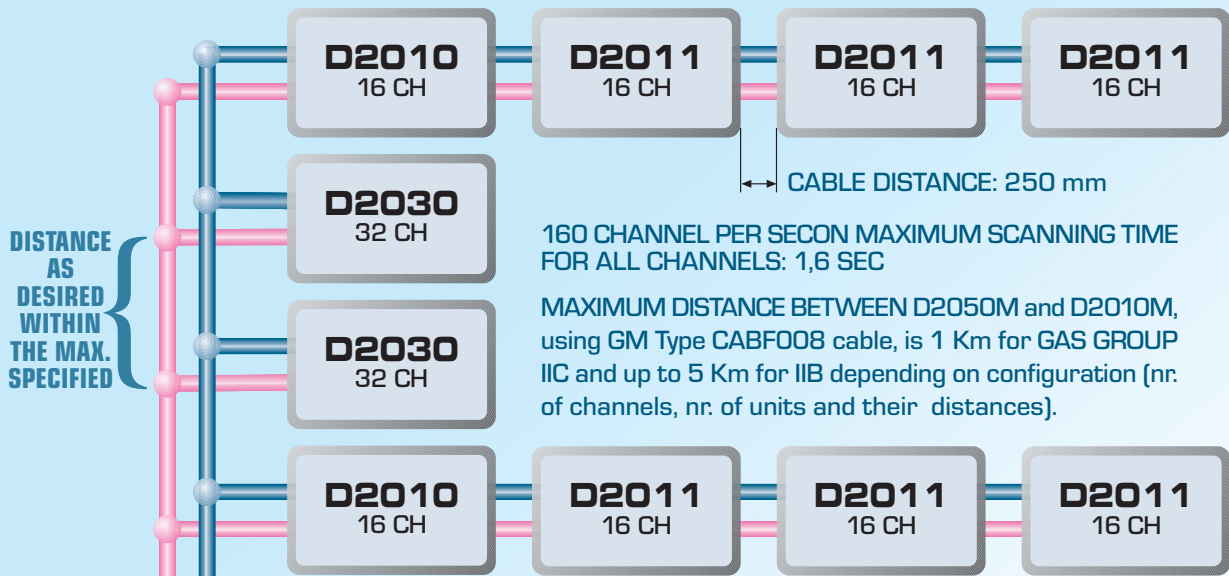

**SAFE AREA**

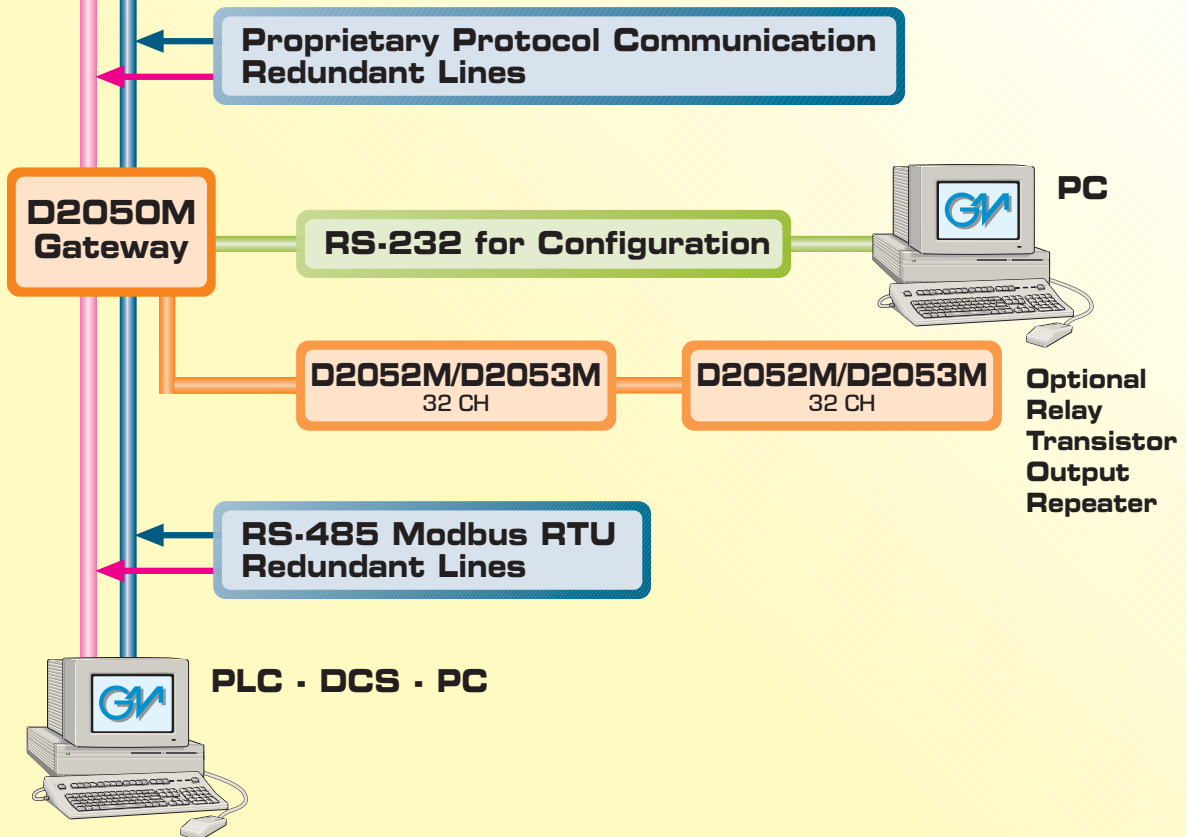

Configuring **D2010M,**  
**D2011M, D2030M**  
Field Units Using  
a PC Serial Line via  
the **Gateway D2050M.**  
Configuration Software  
Available, free of charge,  
from G.M. web site.

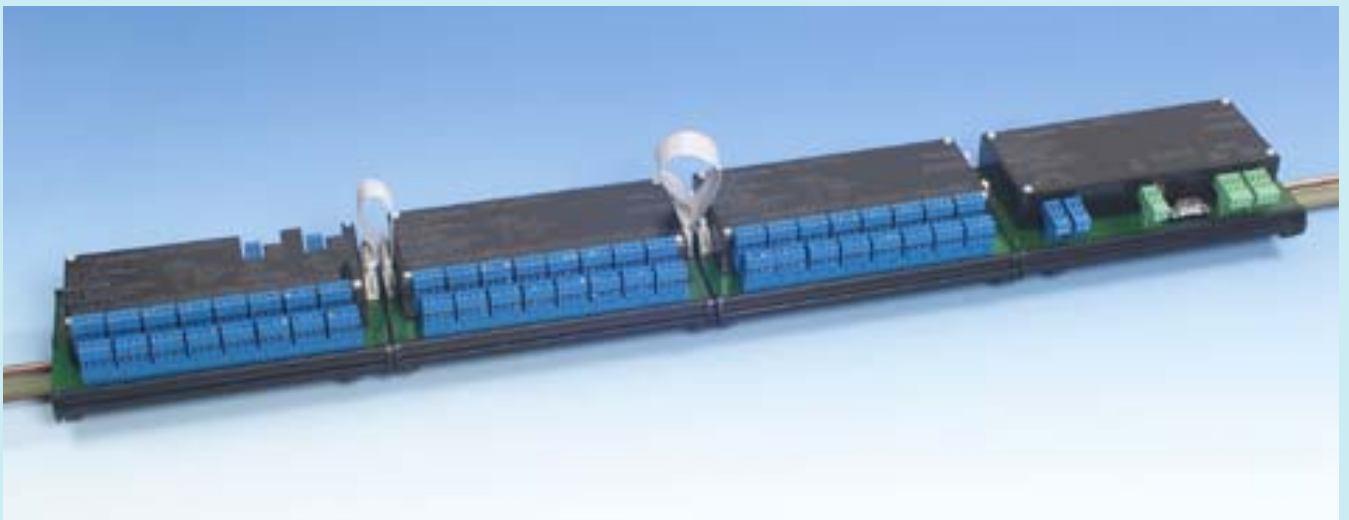

## SWC2090 GRAPHICAL LAYOUT

The SWC 2090 is the software to configure the D2000M Series Multiplexer System.

It is available from our website free of charge together with a "Quick start guide".

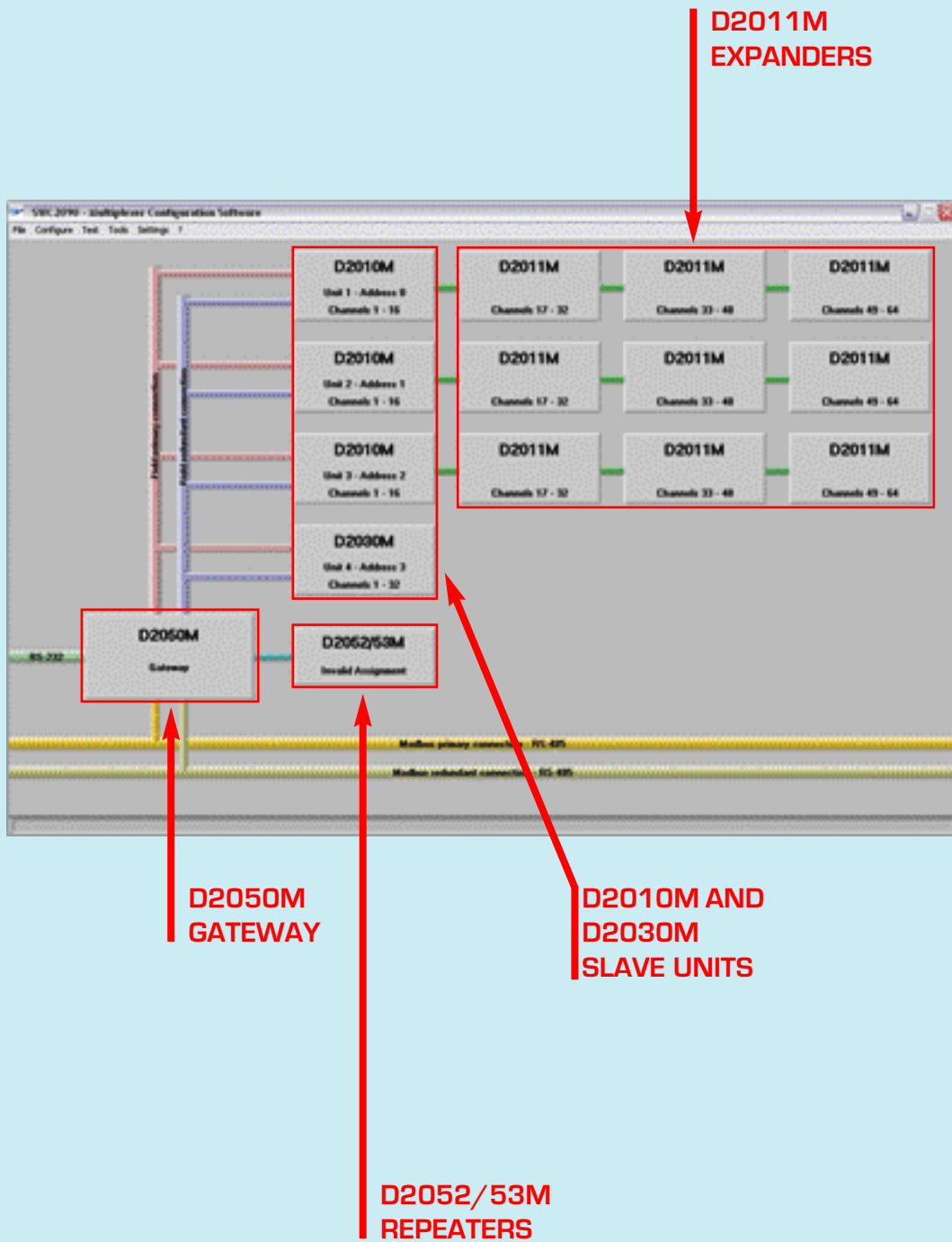

Unit configuration is accessed by double-clicking the corresponding icon in the layout.

PROGRAMMING 16 CHANNELS  
 D2010M AND D2011M  
 ANALOG-TEMPERATURE UNITS

CHANNEL TAG

OPERATING MODE  
SELECTION

AVERAGE FILTER  
SELECTION

Channel	Tag	Scale	Operating Mode	Average Filter
1	Tag 1.01	-20.000 to +20.000 mV	Burnout Up-Scale	No Filter
2	Tag 1.02	Resistance 0.0 to 400.0 Ohm	3 Wire connection	Fast Filter
3	Tag 1.03	Thermocouple type B	No Burnout	Medium Filter
4	Tag 1.04	Thermores. Pt 100 a=385	4 Wire connection	Slow Filter
5	Tag 1.05	Channel Off		
6	Tag 1.06	Channel Off		
7	Tag 1.07	-20.00 to +20.00 mV		
8	Tag 1.08	Resistance 0.0 to 400.0 Ohm		
9	Tag 1.09	Thermocouple type B		
10	Tag 1.10	Thermocouple type E		
11	Tag 1.11	Thermocouple type J		
12	Tag 1.12	Thermocouple type K		
13	Tag 1.13	Thermocouple type L - DIN		
14	Tag 1.14	Thermocouple type L - GOST		
15	Tag 1.15	Thermocouple type N		
16	Tag 1.16	Thermocouple type R		

20.0 Fixed Cold Junction

SENSOR TYPE SELECTION

VALUE FOR FIXED  
COLD JUNCTION  
COMPENSATION

## PROGRAMMING 32 CHANNELS D2030M DIGITAL INPUT UNIT

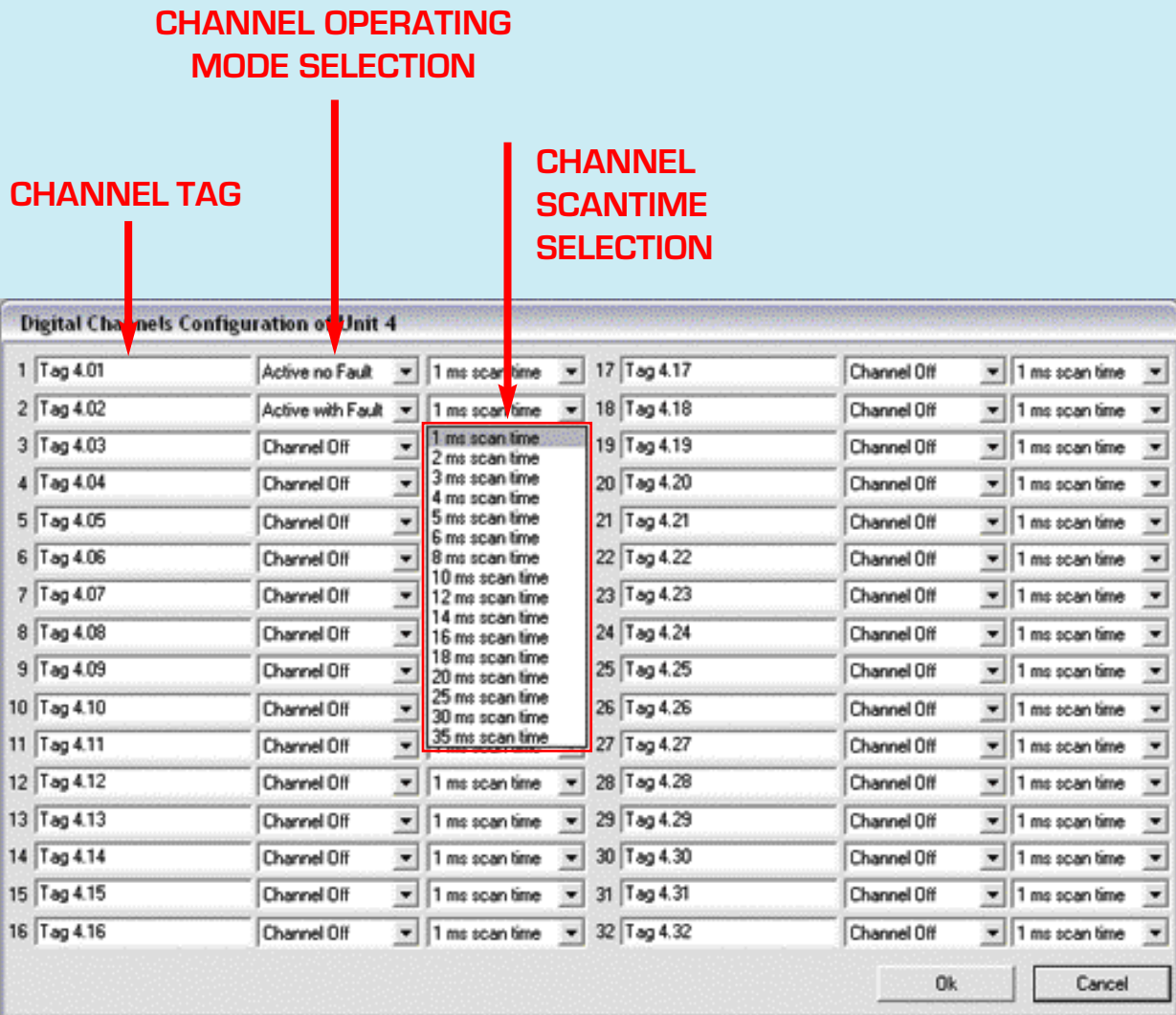

## PROGRAMMING D2050M MULTIPLEXER GATEWAY

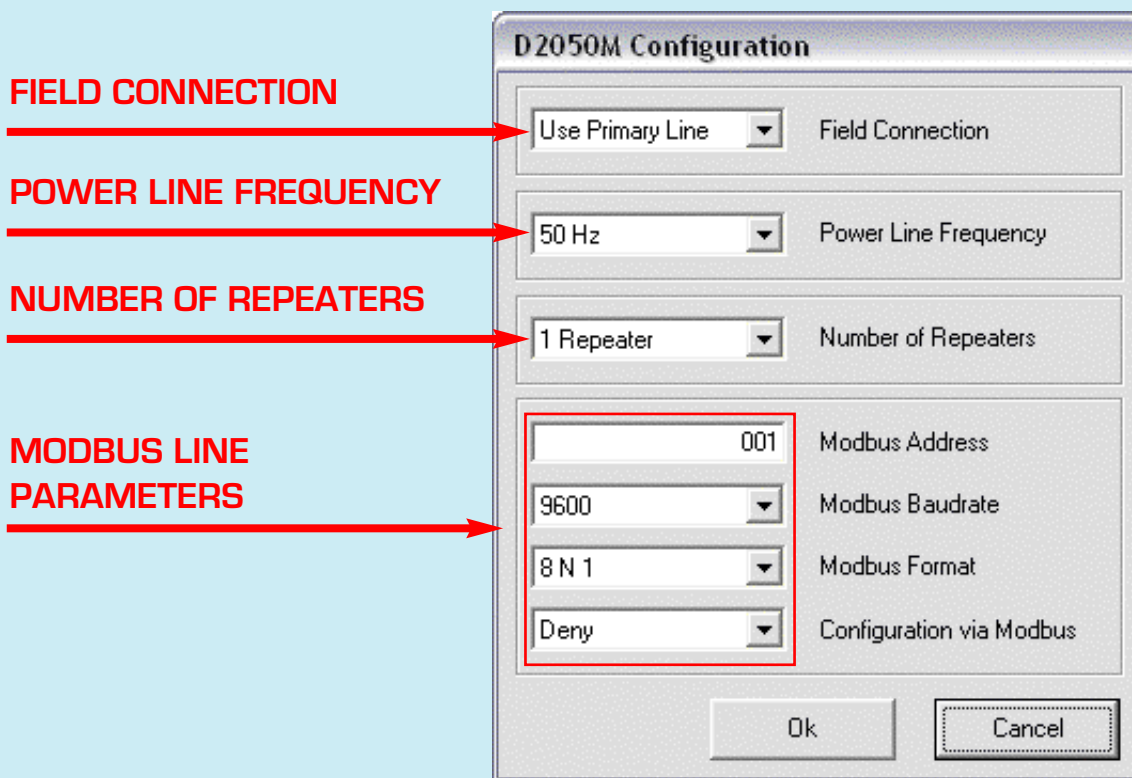

## PROGRAMMING D2052/53M

## CONTACT-PROXIMITY OUTPUT REPEATERS

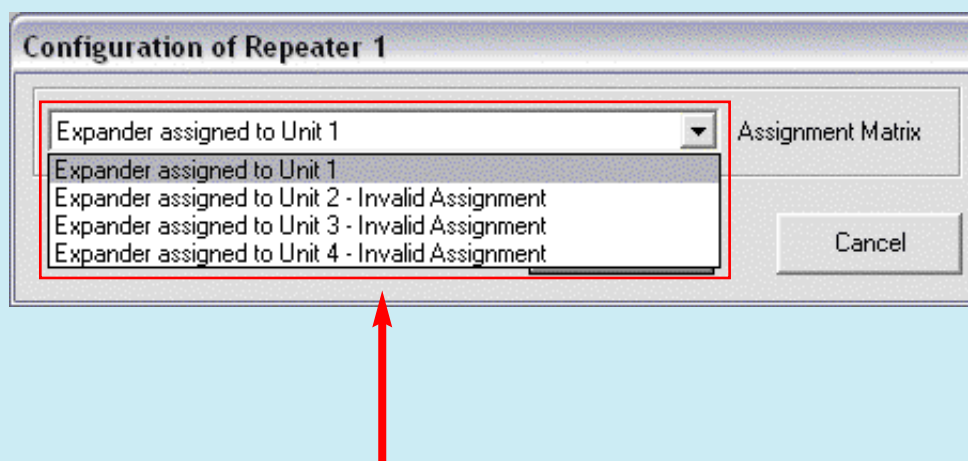

**SELECTION OF D2030M  
SLAVE TO BE REPEATED**

