

ECOTROL®



ARCA
VALVES
*quality engineered
control valves*

ECOTROL® Type Code

0. Operating Data medium: temp.: pressure p1: pressure p2:	7. Body Material 1) 1 - 0.7043 2 - 1.0619 3 - 1.4581 4 - 1.7357 5 - 1.1138 6 - A216 WCB 7 - A351 CF8M 8 - A217 WC6 9 - others (defined in order)	16. Sealing Seat/Plug 1) 0 - leakage class IV-metal-to-metal 1 - leakage class V (met., fine machined) 2 - soft sealing PTFE/EPDM 3 - soft sealing PTFE/VITON 4 - soft sealing PTFE/Trapezoidal 5 - soft sealing square 6 - soft sealing PTFE O-Ring 7 - soft sealing NBR O-Ring 9 - special (defined in order)
1. Series 8C low pressure DN15-100, PN16-40 6N low pressure DN150-400, PN16-40 6H high pressure DN25-200, PN63-250	8. Guiding 1) 0 - stem guiding (standard) 1 - bottom guided in seat 2 - bottom guided in blind flange 9 - special (defined in order)	17. Cage Retainer 1) 0 - standard 1 - LN (low noise) 2 - cage retainer controlled 9 - special (defined in order)
2. Top Flange 1) 1 - standard, with central fastened actuator 2 - with short extension, double stuffing box 3 - with cooling fins 4 - with bellows sealing 5 - with extension (insulation column) 6 - standard (8C DN15-65 integrated in yoke) 7 - standard balanced 8 - with cooling fins, balanced 9 - special (defined in order)	9. kv-Value xxxx - acc. to order 10. Characteristic l - linear g - equal-percentage s - on/off m - modified	18. Low-Noise Cage 1) 0 - standard (none) 1 - LK1 2 - LK2 3 - LK3 4 - LK4 5 - SLK1 6 - SLK2 9 - special (defined in order)
3. Plug Design 1) P1-P5 parabolic plug (1-5 step) L1-L4 perforated plug (1-4 step) S on/off plug	11. Plug Material 1) 1 - 1.4571 2 - 1.4021 3 - 1.4112 4 - 1.4122 9 - others (defined in order)	19. Stem Sealing 1) 1 - PTFE/V-Ring/EPDM Quadrang 2 - PTFE/V-Ring/VITON Quadrang 3 - Latty 6118/ETF Inconel 4 - graphite 0901 5 - graphite/PTFE 6303 9 - special (defined in order)
4. Nominal Diameter (DN) DIN / ANSI: 15 / 1/2" - only series 8C 20 / 3/4" - only series 8C 25 / 1" - 32 - only series 8C 40 / 1 1/2" - 50 / 2" - 65 - only series 8C 80 / 3" - 100 / 4" - 150 / 6" - 200 / 8" -	12. Wear Protection of Plug 1) 0 - standard (none) 1 - nitrated 2 - hardened 3 - sealing edge stellite 4 - complete stellite 5 - kolsterisiert® 9 - special (defined in order)	20. Design Option 0 - standard 1 - NACE 2 - oxygen 9 - special (defined in order)
5. Nominal Pressure (PN) 16 - PN 16 25 - PN 25 40 - PN 40 63 - PN 63 100 - PN 100 160 - PN 160 250 - PN 250 150 - ANSI class 150 acc. to ANSI B16.10 300 - ANSI class 300 acc. to ANSI B16.10 600 - ANSI class 600 acc. to ANSI B16.10 900 - ANSI class 900 acc. to ANSI B16.10 1500 - ANSI class 1500 acc. to ANSI B16.10	13. Balancing 1) 0 - standard (none) 1 - piston ring 2 - EPDM-Quadrang 3 - VITON-Quadrang 4 - graphite 5 - Glydring 9 - special (defined in order)	21. Material inspection 0 - none 1 - PED 2 - EN 10204-2.1 3 - EN 10204-2.2 4 - EN 10204-3.1B 5 - EN 10204-3.1A 6 - EN 10204-3.1C 7 - EN 10204-3.1B TRD 110 class 2 8 - EN 10204-3.1A TRD 110 class 1 9 - AD 2000 10 - others (defined in order)
6. Connections 1) 0 - flanges with packing strip (standard) 1 - flanges with slot 2 - flanges with spring 3 - flanges with spigot and socket 4 - welding ends 5 - butt welded ends 6 - sleeve welded ends 7 - ring type joint (RTJ) 9 - special (defined in order)	14. Seat Material 1) 1 - 1.4571 2 - 1.4021 3 - 1.4112 4 - 1.4122 9 - others (defined in order)	22. Final Inspection 0 - none 1 - PED 2 - EN 10204-2.1 3 - EN 10204-2.2 4 - EN 10204-3.1B 5 - EN 10204-3.1A 6 - EN 10204-3.1C 7 - EN 10204-3.1B TRD 110 class 1 8 - EN 10204-3.1A TRD 110 class 1 9 - AD 2000 10 - others (defined in order)
	15. Wear Protection of Seat 1) 0 - standard (none) 1 - nitrated 2 - hardened 3 - sealing edge stellite 4 - complete stellite 5 - kolsterisiert 9 - special (defined in order)	

1) acc. to specification of customer or is chosen by manufacturer acc. to given data (medium, pressure, temperature etc.)

e.g.:

8C - 1 - P1 - 15 - 16 - 0 - 0

item 1-7 / basic data

series 8C - with standard top flange - 1-step parabolic plug - DN15 - PN16 - with standard flanges - body material 0.7043

0 - 4 - g - 2 - 0 - 0 - 2 - 0 - 0 - 0 - 0 - 1

item 8-19 / trim

simple stem guiding - kv 4 - equal-percentage - plug made of 1.4021 - no wear protection - not balanced - seat made of 1.4021 - no seat wear protection - leakage class IV - no spacer cage - no low-noise cage - stem sealing PTFE-V-Ring/EPDM Quadrang

0 - 1 - 1

item 20-22 / Design/inspections

standard design - material inspection acc. to PED - final inspection acc. to PED

⇒ specifications in the technical bulletin are arranged acc. to this code, e.g. 6.2 = flanges with spring

10 Commandments to Develop the New Control Valve ECOTROL®

<p>Reliability</p> <p>1</p> <p>on highest priority. This product is based on our experience of over 50 years.</p>	<p>Develop what the Customer Requires</p> <p>2</p> <p>For this reason we asked him, evaluated his feedback and incorporated the result to the design of this control valve.</p>	<p>Progress</p> <p>3</p> <p>By developing a digital positioner of the second generation with the option of bi-directional communication.</p>
<p>Flexibility</p> <p>4</p> <p>Invention of a compact, pipeless and vibration resistant positioner mounting which guarantees quick assembly and high reliability for all actuator functions.</p>	<p>Cost of Ownership</p> <p>5</p> <p>Decrease of operating and maintenance cost, (in addition). The SWS-seat (quick-changeable trim combination) for example offers the option of a double-side use by reversing the seat ring (results from this procedure).</p>	<p>Environmental Awareness</p> <p>6</p> <p>By a stem sealing that meets today's requirements by providing a corrosion resistant stuffing box area.</p>
<p>Efficiency</p> <p>7</p> <p>Double use of auxiliary energy by using the umpteenth thousand times tried and tested pneumatic multi-spring diaphragm actuator with the option of permanent spring case ventilation.</p>	<p>Universal</p> <p>8</p> <p>Design according to DIN or ANSI with standardised trims.</p>	<p>Precision</p> <p>9</p> <p>Avoiding misalignment between actuator and valve guiding by applying of up-to-date CNC manufacturing techniques.</p>
<p>Control of the „Magic Triangle“</p> <p>10</p> <p>Shortening the delivery time, minimising the cost with at the same time higher technical value, improvements and quality.</p>	<p>The result is called</p> <p>ECOTROL®</p> <p>A new control valve without any compromise. Perfect with regard to quality, efficiency, weight and ease of maintenance - a valve of which others claim that it is impossible.</p>	

ECOTROL®

The valve series **ARCA-ECOTROL** is a robust, compact and lightweight control valve with a pneumatically operated, easy field reversible multi-spring diaphragm actuator **ARCAPAQ 812** and a sturdy, pipeless and vibration-resistant mounted digital positioner **ARCAPRO 827A**. Optional, the actuator can be equipped with a fully enclosed emergency handwheel which is in compliance with general safety precautions (1). The high-light of this valve series is the **ARCA-double-life** (quick-changeable trim combination) with the option of a double-side use by reversing the seat ring (10). Because of its simple geometry the valve seat can be economically produced in different materials like for example steel, hardened and stellite steel, ceramic, Tungsten carbide, etc., with or without soft sealing. In comparison to conventional designs the speciality of the ECOTROL's soft sealing is, that the PTFE-element is flexibly supported by an additional Elastomer O-Ring. Both sealing elements are located in the seat ring and not as usual in the valve plug. The additional metal-to-metal sealing of plug and seat ring ensures that the PTFE-disc suitable for double-side use is not plastically deformed by excessive loads.

The remarkable difference between the common screwed-in seat ring and this unique quick-change(able) trim combination shown in the figures hereinafter is given by the principle of retaining and sealing the seat ring in the valve body. With a screwed-in seat ring the sealing between seat and valve body is provided by the metal-to-metal contact of two conical faces.

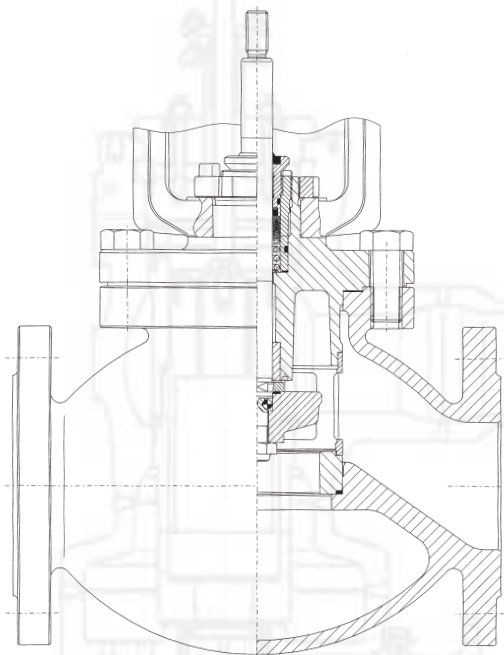

8C

6N

6H



Series 8C1

The conical counter-face in the valve body has a slightly different angle so that there is only a theoretical circumferential line contact. The required torque to screw-in the seat ring is individually different depending on the construction and the operating conditions. With the **ARCA-ECOTROL** valve series the seat sealing is done purely axial and achieved by the method of initial compression.

The compression of the sealing elements (6, 11) is limited by the precisely sized recess in the body for containment of the flat gasket. This limits the gasket's compressive loading and guarantees a perfect alignment between the sealing surfaces of plug and seat ring.

The self-aligning seat ring (10) is hold by the retaining cage (9). The tightness is achieved by transferring a portion of the bonnet-to-body bolting force via the retaining cage to the seat ring. The valve body (12), retaining cage, and seat ring are manufactured on special CNC-machining centres to meet the stringent tolerance of each part. This guarantees the required compression of the sealing elements. Excellent stem guiding is performed by two special guide bushings (4, 8) located as far as possible from each other.

The Profitable Solution: ECOTROL®

“New” is also the standard spring energised stem seal configuration including a PTFE-V-Ring packing set (5) with an additional micro-sealing element and wiper ring (3). The PTFE-V-Ring packing set is pre-loaded by a stainless steel spring and pressed against the valve stem and the bonnet insert (7). The packing set acts as primary sealing and as wiper. The valve stem is guided at two locations right before and behind the stem sealing (5). Besides of the extremely reliable sealing performance even under varying operating temperatures the stem sealing provides minimised static and sliding friction forces in comparison to conventional stuffing box packings.

➔ Cost Saving Benefits

- ✓ excellent performance in liquid and gas applications
- ✓ extended lifetime due to double-side use by reversing the seat ring (10; upper and lower side)
- ✓ easy and fast assembly, maintenance without any special tools
- ✓ low cost performance ratio
- ✓ prevention of leakage (5) and bypass leakage by a limited compressive load acting on both encapsulated gaskets (6, 11)
- ✓ multiple material options
- ✓ optimal flow conditions by seat retaining cage (9)
- ✓ optional: PTFE-soft seat sealing with back-up O-Ring and metal-to-metal end stop
- ✓ alternatively to the pipeless positioner mounting: mounting acc. to DIN IEC 534 T6 (NAMUR)

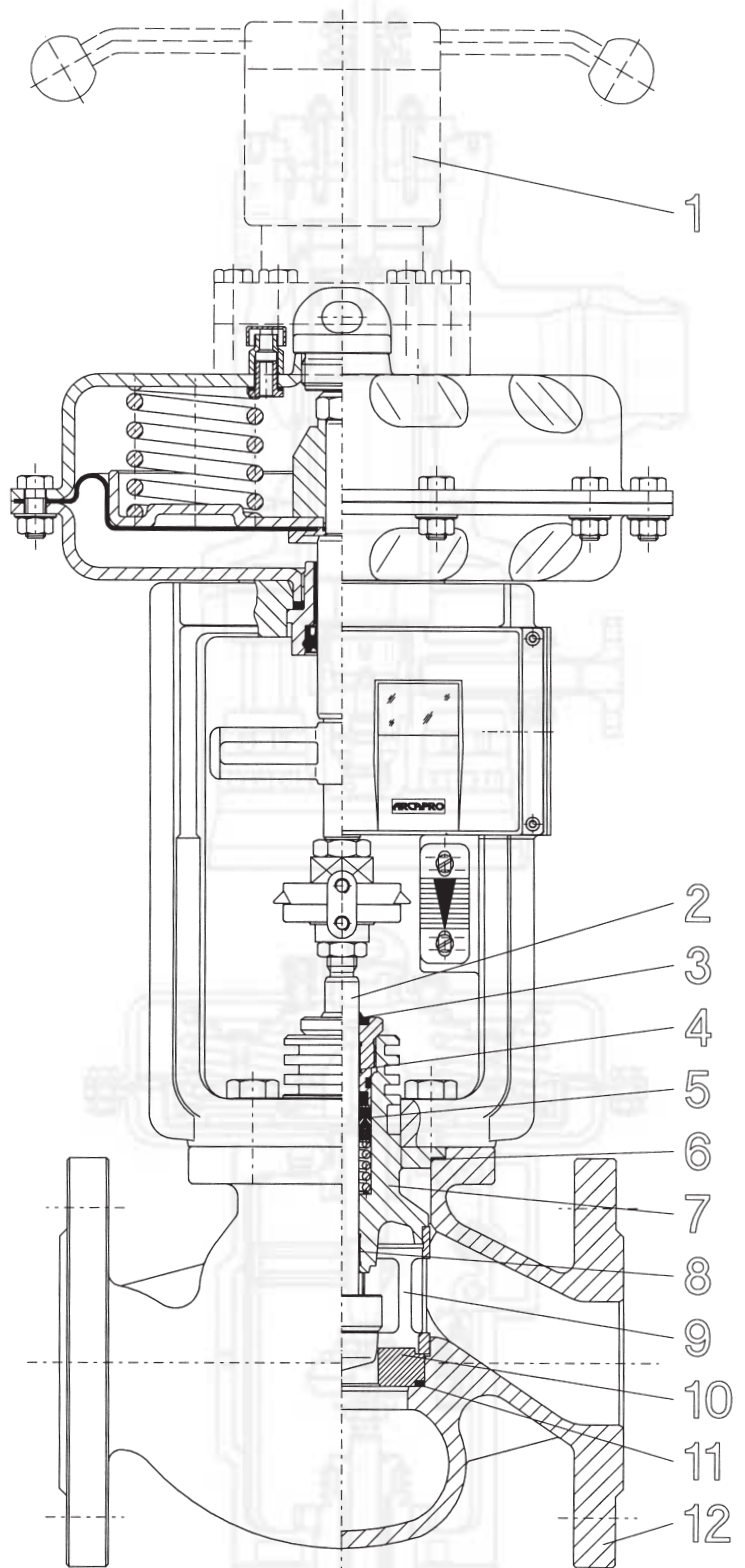

Stem sealing

Depending on the operating conditions, the stem sealing consists of a special sealing configuration to ensure lowest fugitive emission and minimised friction. The stem and the packing bore provide a super finished surface manufactured by the so-called roller burnishing process. This process compresses the surface and increases its hardness.

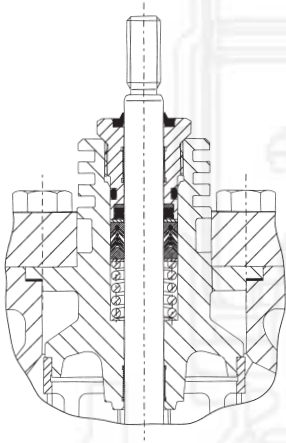

The Standard Maintenance-free PTFE-V-Ring Packing with a Micro-Sealing Element

To guarantee the sealing performance at very low pressures, the PTFE-V-ring packing set is preloaded by a corrosion resistant spring. In normal operation the sealing lips are pressed against the stem and the packing bore relative to the fluid pressure (pressure energised).

To resist the internal pressure resulting from alternating operating conditions the V-Ring set is made of different compounds. The outer packin consists of PTFE with a graphite filling and the centre ring is made of pure PTFE.

The bottom base ring in the V-Ring set acts as wiper and just allows a small amount of fluid to reach the micro-sealing element. This final sealing element is made of a special Elastomer material. Its distance from the top wiper ring is equal to the maximum stroke length. While the valve remains in open position dirt or any kind of stain may accumulate on the stem part right above the top wiper ring. When the stem moves to the closed position some stain may pass the wiper ring, however, it will never approach the micro-sealing element and cause this element to fail.

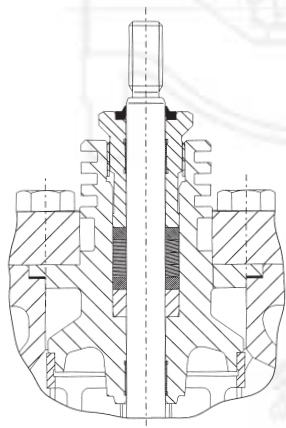

Graphite Stuffing Box

A reliable and safe packing assembly requires a homogeneous compression of the entire set of graphite packings. The screwed stuffing box transfers the compressive load to each packing in the stuffing box. This is similar to the hydrostatic principle of pressure distribution in a fluid. To achieve a steady homogeneous compression of all packings, the lower rings must be compressed more than the upper ones during assembly. To realise this the patented ARCA-OPTIPRESS pre-loading device, activated by the actuator, is recommended.

If the packing loading is simply done by tightening the screwed stuffing box there is the risk of an unequal compression of each packing. In such case the upper rings are compressed more than the lower ones due to frictional forces. This leads to an unfavourable non-homogeneous compression of each ring. Since only the top packing tightly seals, it comes to an early leakage in service and the torque demand also increases. As a consequence, the torque transferred from the screwed stuffing box must be applied with care, so that the packing sealing becomes effective, while the hysteresis does not become too high.

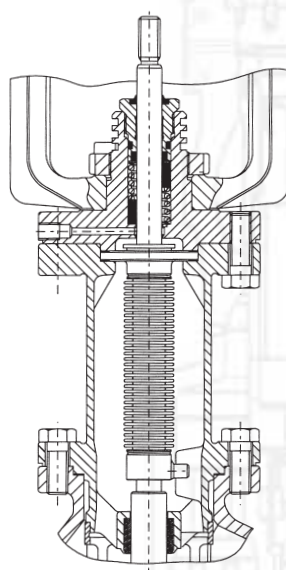

Bellows Seal Bonnet

Hermetically sealing bellows are available for process fluids when no stem leakage can be tolerated (e.g. toxic fluids). The pressure-proof and elastic stainless steel bellows is tightly seal-welded to the valve stem and the upper adapter ring. For safety reasons the construction includes a standard stem sealing as back-up in case of a bellows failure. Between bellows and packing a tapped hole with a plug screw is optionally supplied, either to be used as leak detection, bleed-off, or for inserting a blocking gas.

The voluminous bellows housing provides a reasonable flow velocity around the bellows and, therefore, reduces the susceptibility of the

bellows against crystallising fluids or polymers. The design is equipped with a built-in twist protection that safely keeps the torque caused either by fluid forces or by improper handling away from the bellows, a guarantee against sudden bellows failure and the resulting shutdown and repair costs. Of course, the ARCA bellows sealing is in full compliance with TA-Luft (German Clear Air Act) and ISO 15848 (Draft).

Stem Sealing

Wear Resistant Bushing

To prevent galvanic corrosion between the bonnet stuffing box (carbon steel) and the packing (graphite), all bonnets of valves larger than DN 65 (NPS 2,5") offer a special treated stainless steel bushing. For valves equal or less than DN 65, the bonnet is always made of stainless steel.

The bushing with a straight through bore allows superfinishing of the surface which ensures perfect sealing between packing or sealing ring and bushing. The stainless steel bushing avoids or minimises any corrosion and spoiling in the vicinity of the sealing.

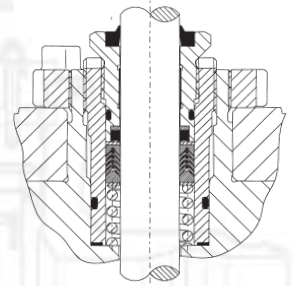

Bonnet Extension for Cryogenic Service

The cross sectional drawing shows the principle design of the newly developed ECOTROL®-control valve for cryogenic service. The valve plug and stem extension are double guided. The bottom guiding is located right below the valve seat. This guarantees a reliable sealing performance, a vibration free guiding of the plug, and an easy replacement of the guide bushing. Each part which is subject to wear can be individually replaced. The seat is axially restrained by the retaining cage and the top flange.

The bonnet extension prevents icing of the packing area. The thin walls of the insulation column and of the stem extension allow only a very low conductive heat flow. In addition, the stem extension pipe is filled with Perlite to reduce convective heat loss to a minimum. The bonnet extension length is based on customer requirements.

All cryogenic valves are assembled apart from ARCA's standard valves in a clean-room environment. Here, the valves undergo a thorough cleaning process in a subsonic bath followed by a complete dehydration in an air circulating dryer.

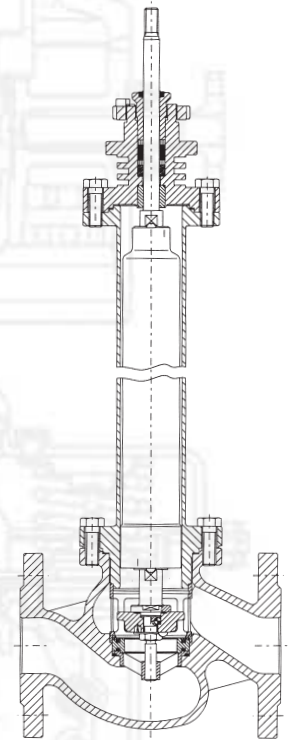

PED Top Flange Design (8C1)

To be in compliance with the European Pressure Equipment Directive (PED) the valve's top flange and actuator yoke (material: austenitic stainless steel) are made of two individual parts. The top flange is permanently attached to the body and untying is unnecessary for dismantling the actuator.

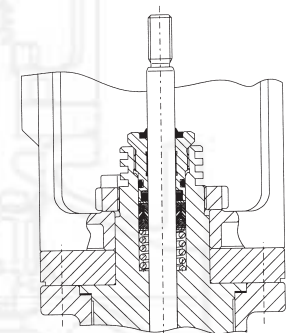

Trim Styles

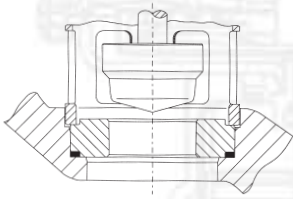

Parabolic Plug (Standard)

Metal-seated quick-changeable trim combination. Insensitive to impurities with low cavitation design. Fast and easy to produce due to its rotational symmetry.

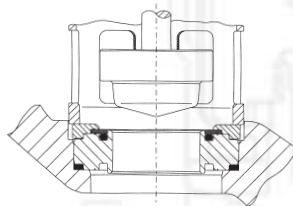

Parabolic Plug with Soft Sealing and Secondary Metal-to-Metal Sealing

Soft-seated quick-changeable trim combination. The PTFE-soft sealing (for unrestricted use on both sides) is flexibly supported by an additional Elastomer O-Ring. The additional metal-to-metal sealing of plug and seat ring ensures that the PTFE-disc is not plastically deformed by excessive loads when the plug reaches its final closed position.

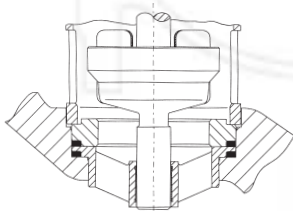

Parabolic Plug Double-Guided

Metal-seated quick-changeable trim combination with top and bottom guiding. This double guiding construction stabilises stem and plug over the full travel range. Therefore, it is recommended for high pressure drop applications.

The additional guiding is located right below the seat ring and can be easily replaced.

Most conventional body designs with top and bottom guided trim have a bolted bottom flange which requires an extra body gasket plus the risk of additional external leakage.

The ECOTROL one-piece body design eliminates this problem and ensures optimum tightness.

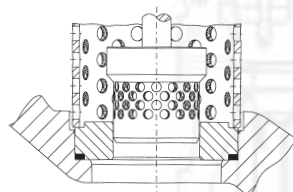

Perforated Plug/Perforated Low Noise Cage

Metal-seated quick-changeable trim combination. Particular effective for liquids and compressible fluids at high pressure drop ratios. Liquid flow can cause erosion by cavitation. The flow, directed through the holes of the trim, is divided into numerous jets of cavitating liquid.

In the centre of the cage the jets impact and the vapour bubbles collapse. Here, they do not cause any damage to the valve internals and the noise level is also considerably reduced. For more noise abatement a perforated low noise cage is available for all trim designs.

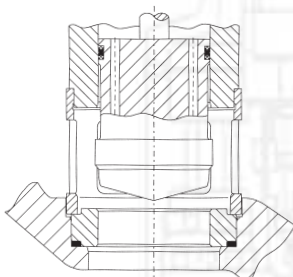

Balanced Trim

Valves with balanced trims require much lower control forces than valves without balancing. As sealing elements we offer:

- metallic piston rings
- Elastomer Quadrings with PTFE support
- pure graphite

Trim Styles/Precautions against Wear and Tear

On/Off Plug (Soft-Sealing / Double-Guided also available)

This plug is designed where a significant flow rate must be quickly established; also available with soft seat and top and bottom guiding.

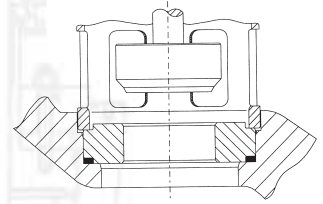

Stellited Seating Surfaces

(hardened to 39-43 Rockwell C for elevated applications).

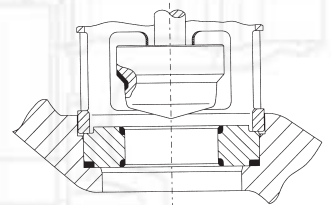

Excellent Wear Resistant Trim

Material 1.4112 (hardened to > 58 Rockwell C) other harder alloys or special ceramics for extreme applications on request (hardened up to 2000/2600 HVI).

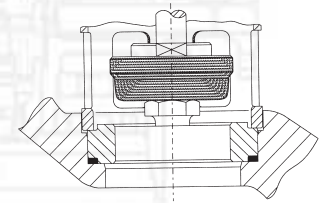

Quick Changeable Trim

Parabolic and perforated plug. Quick and easy exchange of throttle without any special tools. Several material combinations possible, in particular for hard metal and ceramic execution.

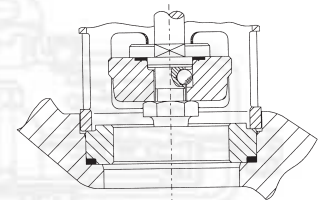

In a control valve the throttling process is principally the conversion of potential energy (pressure) into kinetic energy (velocity). Due to design constraints the maximum velocity occurs at the orifice between plug and seat ring. Especially at high pressure drops the sealing surfaces and the contours of seat ring and parabolic plug must resist extreme erosive effects caused by cavitation, abrasion and high velocity impingement. Because of their simple rotational symmetry the trim elements can be made of alternative materials providing excellent wear resistance like for instance Silicon Nitride, Aluminium Oxide, Tungsten Carbide etc.

Table of comparable body and trim materials

Material	Norm	Europe	ASTM
0.7043 (GGG40.3)	EN 1563	EN-GJS-400-18(A-LT)	-
1.0619 (GS-C25)	EN 10213-2	GP 240 GH	A 216 WCB
1.4021	EN 10088	X 20 Cr 13	A 276 420
1.4112	EN 10088	X 90 CrMoV 18	A 276 440 B
1.4122	EN 10088	X 39 CrMo 17 1	-
1.4408	EN 10213-4	G-X 5 CrNiMo 19 11 2	A 351 CF8M
1.4571	EN 10088	X 6 CrNiMoTi 17 1 2 2	A 276 316 Ti
1.4581	EN 10213-4	G-X 5 CrNiMoNb 19 11 2	-
1.7335	EN 10028-2	13 CrMo 4 5	A 182 F12 Cl.1
1.7357 (GS-17CrMo 5 5)	EN 10213-2	G 17 CrMo 5 5	A 217 WC 6

Table may be used as a general guide only.

⇒ For further trim styles and information, please take a look at the technical bulletin

DS ECOTROL-gb

Pressure-Temperature Diagrams

ASME B16.34 150/300

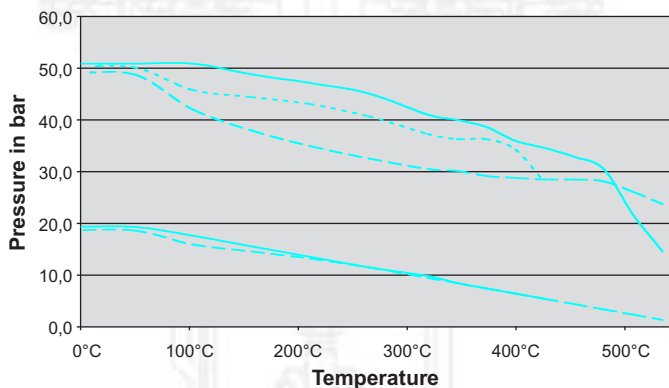

ASME 16.34

ASME B16.34 600/900/1500

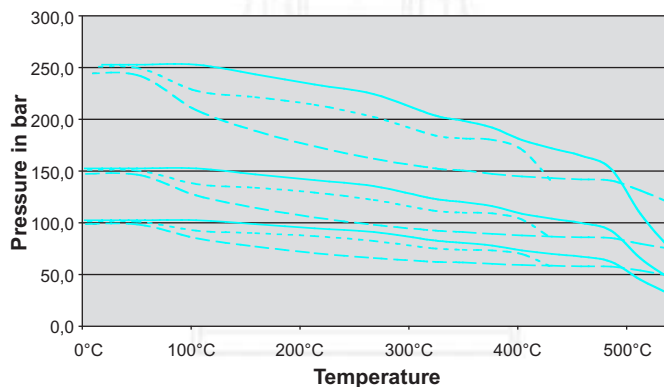

DIN EN 1092-1 PN16, PN25, PN40

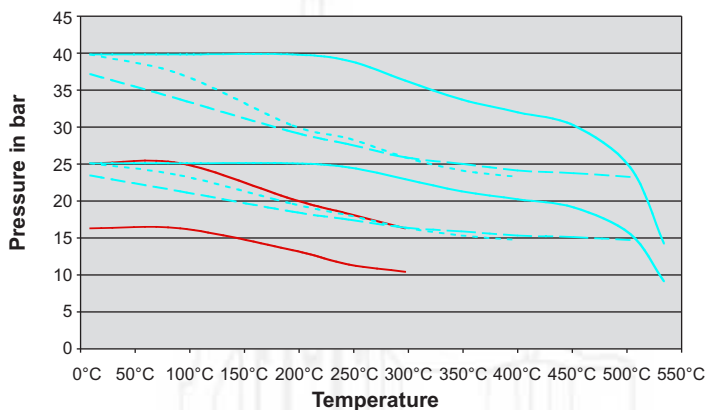

DIN EN 1092-1

DIN EN 1092-1 PN63, PN100, PN160, PN250

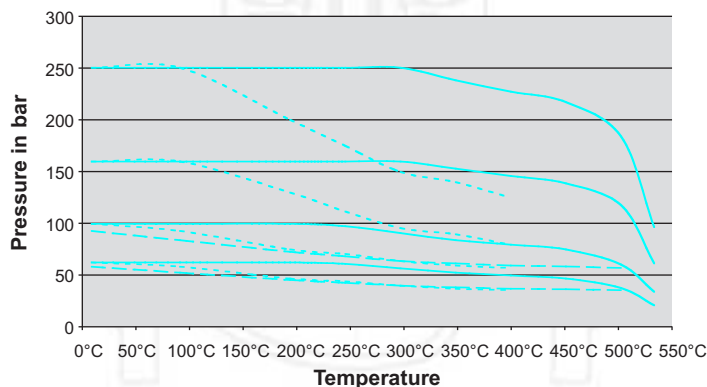

- WC6/1.7357
- - - CF8M/1.4581
- · · WCB/1.0619
- 0.7043

Technical Data and Materials

ECOTROL General Data

Nominal Size	DN 15-400	1/2" – 16"
Pressure Rating	PN 16 – 250	ANSI 150-1500
Material of Body	EN 0.7043 EN-GJS-400-18-A-LT 1.0619 GP240GH 1.4408 G-X 5 CrNiMo 19 11 2 1.4581 GX5CrNiMoNb 19-11-2 1.6220 G20Mn5 1.6982 GX3CrNi13-4 1.7357 G17CrMo5-5	for temperatures -10 to 300°C -10 to 400°C 0 to 300°C -10 to 400°C -40 to 400°C -120 to 400°C -10 to 530°C
		ASTM Gr. 604018 ¹⁾ A 216 WCB A 351 CF8M - A 352 LCB - A 217 WC6
		for temperatures -10°C to 350°C -28°C to 400°C -196°C to 400°C - -50°C to 400°C - -28°C to 530°C
Material of Bonnet	≤ DN 65 in material 1.4571 (ANSI TP316TI) ≥ DN 80 in material same as body but with sealing bushing in 1.4571 (ANSI TP316TI)	
Characteristic of Plug	Standard: equal-percentage Optional: linear	
Rangeability	50:1	
Double Guiding	Optional: integrated double guiding available for series 8C DN40 – DN400, Kvs>40	
Seat Leakage	Metal-to-Metal: Class IV-V (0,1% - 0,001% of kvs) Elastomer-to-Metal: Class VI	
Bellows Sealing	1. 1.4571 weldless double layer or optional in Available for ANSI 150 and ANSI 300, 2. Hastelloy C other pressure classes on request.	
Heating Jacket	Connections DN 15 PN 40 (1/2" ANSI 300) socket screwed or flanged	

1) Only for pressure rating PN 16+25, ANSI 150+300

ECOTROL Standard Trims

Material Code No.	Parabolic Plug	Parabolic plug P1 with Integrated Double Guiding ¹⁾	Perforated Plug L1	Seat	Seat Sealing Type	Temperature of Fluid
1	1.4571	-	-	1.4571	metal-to-metal	acc. to stem sealing
2	-	1.4571	1.4571 nitrated	1.4571	metal-to-metal	acc. to stem sealing
3	-	-	1.4122 nitrated	1.4021	metal-to-metal	acc. to stem sealing
4	1.4112 hardened	1.4112 hardened	1.4112 hardened	1.4112 hardened	metal-to-metal	acc. to stem sealing
5	1.4571	-	-	1.4571	PTFE/EPDM	-50 ~ 140°C
6	1.4571	-	-	1.4571	PTFE	-196 ~ 180°C

1) Only from ≥ DN50 ≥ kvs 40

Permissible Temperature Range for Packings

Sealing Type	Packing Ring (Pos. A)	Micro Sealing (Pos. B)	O-Ring (Pos. C)	Wiper Ring (Pos. D)	Temperature of Fluid	Bonnet Type	Comments
maintenance free, double guiding	PTFE V-Ring	EPDM (VITON)	EPDM	NBR (VITON)	-25 ~ 180 (200)°C	Standard	Live Loaded with SS spring
readjustable ¹⁾	Reinforced Graphite/Inconel	-	-	NBR (VITON)	-20 ~ 400°C	Standard/ Cooling fins	Regular Service
readjustable ¹⁾	Braided/Pure Graphite or Pure Graphite	-	-	VITON	-20 ~ 530°C	Standard/ Cooling fins	High Temperature Service
readjustable ¹⁾	Braided/Pure Graphite or Pure Graphite	-	-	NBR	-196 ~ -20°C	Bonnet Extension	Cryogenic Service
readjustable ¹⁾	Braided Graphit/PTF	-	-	NBR	-196 ~ 200°C	Standard/ Bonnet Extension	Cryogenic Service
bellows sealing with safety double sealing	PTFE V-Ring Bellows in 316 or Hastelloy C	EPDM	EPDM	NBR (VITON)	-100 ~ 200°C	Bellows Sealing	Live Loaded with SS spring
bellows sealing with safety double sealing	Braided Graphit/PTFE	-	-	NBR	-196 ~ 400°C	Bellows Sealing	high and low temperature service

1) also available with self-readjustable stuffing box packing

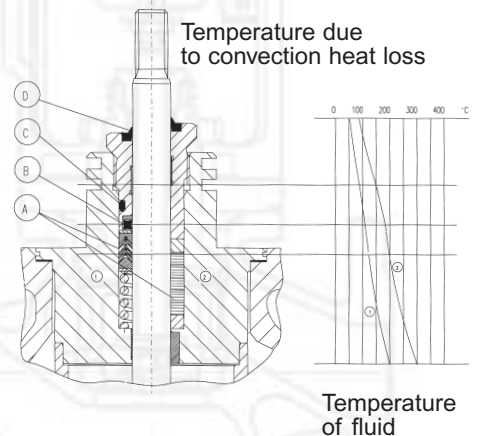

⇒ For further information, please take a look at the technical bulletin

Easy Plug-In Concept

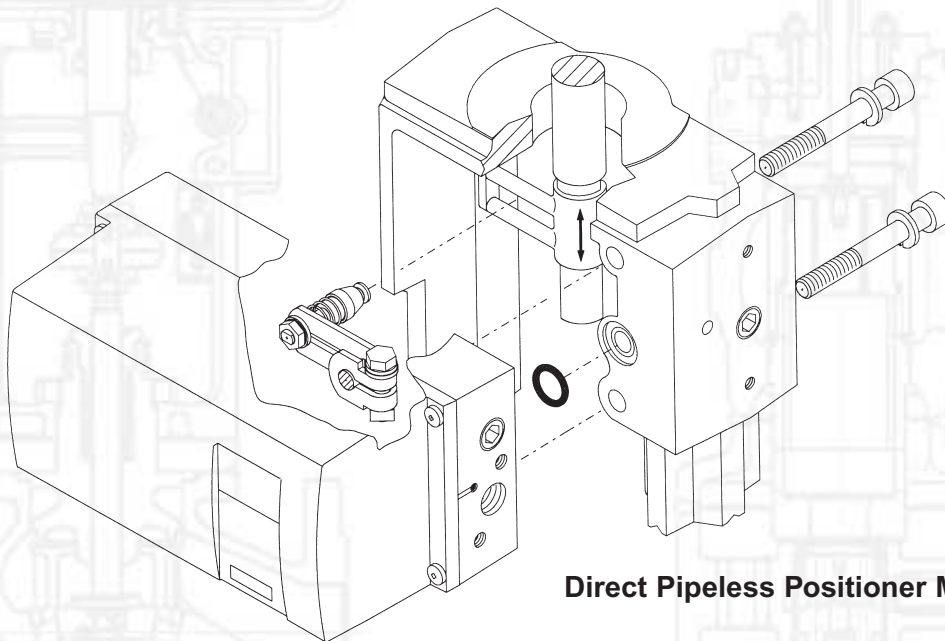

Direct Pipeless Positioner Mounting

The positioner can be easily plugged-in within seconds. At the same time the connection for the outlet actuating pressure and the stroke feedback mechanism is provided without any additional part.

Rugged, vibration-resistant and pipeless positioner mounting adjacent to the post of the yoke guarantees short stroke feedback elements and, therefore, highest control accuracy.

The entire feedback mechanism of the positioner is fully encased between both posts of the yoke. That ensures safe functionality and further incident prevention.

The instrument air supply between positioner and actuator is attained through bores inside the yoke. Since this supply system is entirely pipeless the positioner mounting can be enormously simplified.

The positioner types C, D, and E provides the option of a permanent ventilation of the spring case by clean exhaust instrument air.

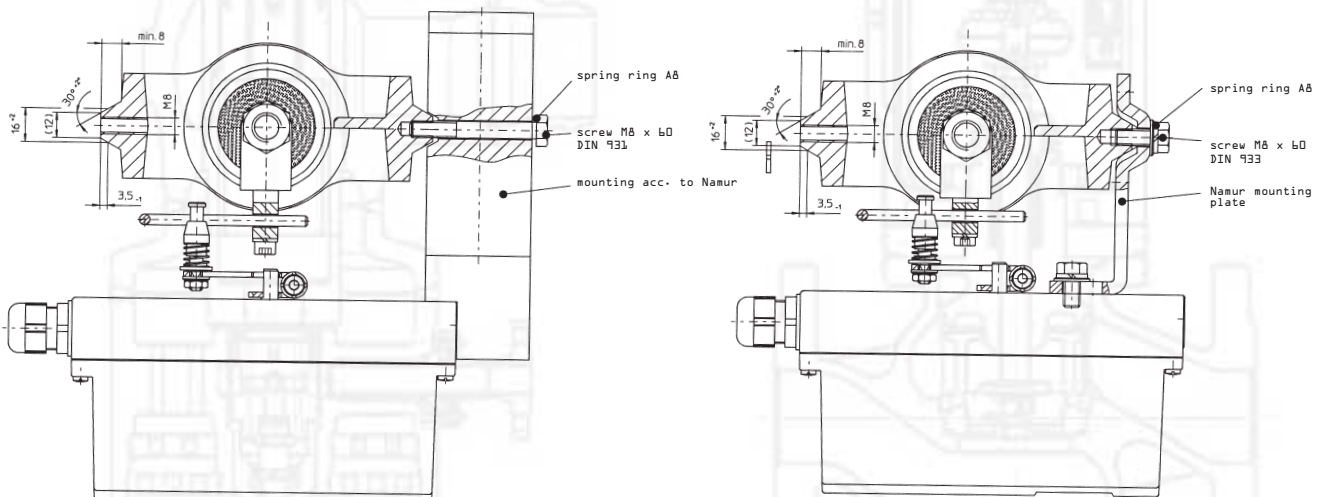

Positioner mounting acc. to DIN IEC 534 T6 (NAMUR)

Mounting of Positioner acc. to VDI/VDE 3847

ARCA series 812 multi-spring actuators support the standardised positioner mounting per VDI/VDE 3847. This interface allows the easy exchange of positioners and solenoid valves made by different manufacturers, without losing the advantages of integrated mounting as:

- high stability even in extreme stress situations caused by vibration and shock
- the pipeless supply of control air to the actuator's diaphragm chamber for fail-to-close action (for pipeless fail-to-open action choose actuator type C).
- direct mounting of solenoid valves per VDI/VDE 3845 (1998).

As special option, the interface is also available with separate block valves for air supply, positioner outlet and solenoid valve outlet. On demand, the valve may be locked, and the positioner / solenoid valve can be exchanged without impact or disturbance to the process itself.



Diaphragm Actuator Series 812

Description

Pneumatically operated multi-spring diaphragm actuator of the new generation. The actuator is easily field reversible without the need of disassembly. The instrument air supply between positioner and actuator is attained through bores inside the yoke providing more reliability in comparison to conventional designs. This method ensures a safe air supply to the actuator and simplifies enormously the positioner mounting. Furthermore, the combination with the positioner type 824 or the digital positioner of the second generation type 827 provides the option of a permanent ventilation of the spring case by clean exhaust instrument air.

During operation there is a minimal overpressure against atmosphere on the backside of the diaphragm plate (spring chamber). This guarantees that during stroke movement no ambient air can be sucked in the spring chamber. This protects the essential inner parts against aggressive atmosphere (like sea air).

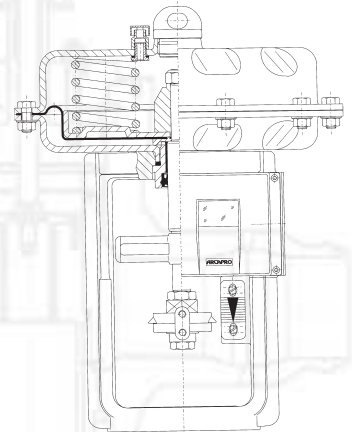

Air to open

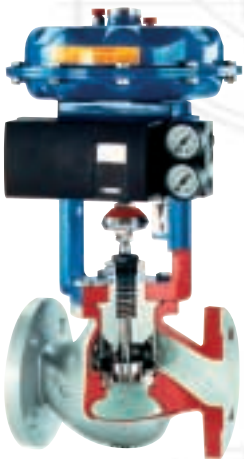

Size	Diaphragm area (cm ²)	Type	No. of springs	Stroke	Air Pressure Range from (bar)	Air Pressure Range to (bar)	Thrust Force (kN)
MFI-20	320	812.25(6)	3	20	0.8	1.5	2.4
MFI-30 (pre-loading)			6		1.5	3.0	4.8
MFI-30		812.23	3		1.0	1.5	3.3
			6		2.0	3.0	6.5
MFIII-30	720	812.33	3	30	0.8	1.5	2.4
			6		1.5	3.0	4.8
			9		0.7	1.5	5.0
			12		1.5	3.0	10.0
MFIII-60 (pre-loading)	720	812.34	3	60	1.8	3.7	13.0
			6		2.2	4.4	16.0
			9		1.1	1.5	8.0
			12		2.2	3.0	16.0
MFIII-60	720	812.34	3	60	2.7	3.6	19.0
			6		3.1	4.3	23.0
			9		0.7	1.5	5.0
			12		1.4	3.0	10.0
					1.7	3.6	12.0
					2.0	4.3	14.0

Air to close



Size	Diaphragm area (cm ²)	Type	No. of springs	Stroke (mm)*	Min. Air press. (bar)	Thrust (kN) depending on Air Pressure				
						2.0 bar	3.0 bar	4.0 bar	5.0 bar	6.0 bar
MFI-20	320	812.25(6)	3	20	1.5	1.6	4.8	8.0	11.2	14.4
			6		3.0		3.2	6.4	9.6	
MFI-30		812.23	3		1.5	1.6	4.8	8.0	11.2	14.4
			6		3.0		3.2	6.4	9.6	
MFIII-30	720	812.33	3	30	1.5	3.6	10.8	18.0	25.2	32.4
			6		3.0		7.2	14.4	21.6	
			9		3.7		2.2	9.4	16.6	
			12		4.4			4.3	11.5	
MFIII-60	720	812.34	3	60	1.5	3.6	10.8	18	25.2	32.4
			6		3.0		7.2	14.4	21.6	
			9		3.6		2.9	10.1	17.3	
			12		4.3			5.0	12.2	

* 8C DN15 (1/2") – DN65 (2 1/2") parabolic plug (P1) – valve stroke 16 mm
 multihole cage (L1) – valve stroke 20 mm

Diaphragm Actuator Series 811 and MA

Air to open

Size	Diaphragm area (cm ²)	Type	No. of springs	Stroke (mm)	Air Pressure Range		Thrust Force
					from (bar)	to (bar)	
UV-60	1440	811.41	1	60	0.1	1.8	14.4
UV-100		811.43	1	100	0.1	1.4	8.4
UV-120		811.47	1	120	0.0	3.0	8.6
MA3.60A 25 mm (pre-loading)	2047 (1715)*	2G	2	60	0.6	0.9	10.1
		4G	4		1.1	1.9	20.2
		6G	6		1.7	2.8	30.3
		8G	8		2.3	3.7	40.4
MA3.60D 25 mm (pre-loading)	2047 (1715)*	2R	2	100	0.5	1.3	8.7
		4R	4		1.0	2.6	17.4
		6R	6		1.5	3.9	26.1
		8R	8		2.0	5.3	34.8
MA3.60D 5 mm (pre-loading)	2157 (1544)*	2R	2	120	0.3	1.3	6.6
		4R	4		0.7	2.6	13.2
		6R	6		1.0	3.9	19.7
		8R	8		1.4	5.3	26.3

Air to close

Size	Diaphragm area (cm ²)	Type	No. of springs	Stroke (mm)	Min. Air press. (bar)	Thrust force (kN) depending on Air Pressure					
						1.4bar	2.0bar	3.0bar	4.0bar	5.0bar	6.0bar
UV-60	1440	811.41	1	60	0.8	9.7	18.4	32.8	43.6	65.3	76.2
UV-100		811.43	1	100	0.8	7.9	16.5	30.9	41.7	63.3	74.1
MA3.60A 25 mm (pre-loading)	1853 (2185)**	2G	2	60	0.8	12.0	23.0	41.5	60.0	78.5	97.0
		4G	4		1.6	-	9.0	27.5	46.0	64.5	83.0
		6G	6		2.4	-	-	14.0	32.5	51.0	69.5
		8G	8		3.2	-	-	-	18.5	37.0	55.5
MA3.60D 25 mm (pre-loading)	1652 (2185)**	2R	2	100	1.1	6.0	16.0	32.5	49.0	65.5	82.0
		4R	4		2.2	-	-	15.5	32.0	48.5	65.0
		6R	6		3.3	-	-	-	15.0	31.5	48.0
		8R	8		4.4	-	-	-	-	14.5	31.0
MA3.60D 5 mm (pre-loading)	1566 (2185)**	2R	2	120	1.3	4.5	12.0	27.5	43.5	59.0	74.5
		4R	4		2.6	-	-	8.5	24.0	40.0	55.5
		6R	6		3.9	-	-	-	5.0	20.5	36.5
		8R	8		5.2	-	-	-	-	1.5	17.5

*) at 100% **) at 0%

Maximum Allowable Differential Pressure in BAR for Metal Seated Valve with Braided Packings

ECOTROL® 8C und 6N PN10, PN16, PN25, PN40 JIS10K, JIS16K, JIS20K, ANSI 150, ANSI 300

Flow to open

Actuator Series 812					Action: Air-to-open No. of springs				Action: Air-to-close No. of springs									
Valve body size DN(mm)	Max. travel (mm)	Actuator size	Flow coefficients		Orifice Ø (mm)	3		6		9		12		Supplied Air Pressure (bar)				
			Kv	Cv		bar	bar	bar	bar	3.0	4.5	6.0	4.5	6.0				
															bar	bar	bar	bar
15 1/2"	16 5/8"	MFI-20 320 cm ² 50 in ²	4.0	4.7	15	50.0							50.0	50.0	50.0	50.0	50.0	
			1.6	1.9	10	50.0								50.0	50.0	50.0	50.0	50.0
			0.63	0.73	5	50.0								50.0	50.0	50.0	50.0	50.0
20 3/4"	16 5/8"	MFI-20 320 cm ² 50 in ²	4.0	4.7	15	50.0							50.0	50.0	50.0	50.0	50.0	
			1.6	1.9	10	50.0								50.0	50.0	50.0	50.0	50.0
			0.63	0.73	5	50.0								50.0	50.0	50.0	50.0	50.0
25 1"	16 5/8"	MFI-20 320 cm ² 50 in ²	10	11.5	25	32.7	50.0						50.0	50.0	50.0	50.0	50.0	
			4.0	4.7	15	50.0	50.0							50.0	50.0	50.0	50.0	50.0
			1.6	1.9	10	50.0	50.0							50.0	50.0	50.0	50.0	50.0
32 1 1/4"	16 5/8"	MFI-20 320 cm ² 50 in ²	10	11.5	25	32.7	50.0						50.0	50.0	50.0	50.0	50.0	
			4	4.7	15	50.0	50.0							50.0	50.0	50.0	50.0	50.0
			1.6	1.9	10	50.0	50.0							50.0	50.0	50.0	50.0	50.0
40 1 1/2"	16 5/8"	MFI-20 320 cm ² 50 in ²	25	29	36	14.1	37.7						37.7	50.0	50.0	37.7	50.0	
			16	19	30	21.6	50.0							50.0	50.0	50.0	50.0	50.0
			10	11.5	25	32.7	50.0							50.0	50.0	50.0	50.0	50.0
50 2"	16 5/8"	MFI-20 320 cm ² 50 in ²	40	46	46	7.1	21.5						21.5	50.0	50.0	21.5	50.0	
			25	29	36	13.1	36.7							36.7	50.0	50.0	36.7	50.0
			16	19	30	20.2	50.0							50.0	50.0	50.0	50.0	50.0
65 2 1/2"	16 5/8"	MFI-20 320 cm ² 50 in ²	63	73	50	5.7	17.9						17.9	42.3	50.0	17.9	42.3	
			40	46	46	7.1	21.5							21.5	50.0	50.0	21.5	50.0
			25	29	36	13.1	36.7							36.7	50.0	50.0	36.7	50.0
80 3"	30 1 3/16"	MFI-30 320 cm ² 50 in ²	100	116	80	1.3	6.1						6.1	15.6	25.2	6.1	15.6	
			63	73	50	5.7	17.9							17.9	42.3	50.0	17.9	42.3
			40	46	46	7.1	21.5							21.5	50.0	50.0	21.5	50.0
		MFIII-30 720 cm ² 111 in ²	100	116	80	6.5	16.4	22.4	28.3				18.8	40.3	50.0	20.0	41.5	
			63	73	50	18.9	44.4	50.0	50.0				50.0	50.0	50.0	50.0	50.0	
			40	46	46	22.7	50.0	50.0	50.0				50.0	50.0	50.0	50.0	50.0	
100 4"	30 1 3/16"	MFI-30 320 cm ² 50 in ²	160	186	100	0.4	3.5						3.5	9.6	15.7	3.5	9.6	
			100	116	80	1.3	6.1							6.1	15.6	25.2	6.1	15.6
			63	73	50	5.7	17.9							17.9	42.3	50.0	17.9	42.3
		MFIII-30 720 cm ² 111 in ²	160	186	100	3.7	10.1	13.9	17.7				11.6	25.4	39.1	12.4	26.1	
			100	116	80	6.5	16.4	22.4	28.3				18.8	40.3	50.0	20.0	41.5	
			63	73	50	18.9	44.4	50.0	50.0				50.0	50.0	50.0	50.0	50.0	
150 6"	60	MFIII-60 720 cm ² 111 in ²	380	445	135	1.6	5.1	7.2	9.3				5.9	13.4	20.9	6.1	13.7	
			260	304	115	2.5	7.3	10.2	13.1				8.4	18.8	29.2	8.8	19.2	
			150	176	90	4.7	12.6	17.3	22.0				14.3	31.3	48.2	14.9	31.9	
200 8"	60	MFIII-60 720 cm ² 111 in ²	650	761	180	0.6	2.6	3.4	4.2				3.0	7.3	11.5	3.2	7.4	
			380	445	135	1.6	5.1	7.2	9.3				5.9	13.4	20.9	6.1	13.7	
			260	304	115	2.5	7.3	10.2	13.1				8.4	18.8	29.2	8.8	19.2	

Actuator Series 811					Spring				Spring							
Valve body size DN(mm)	Max. travel (mm)	Actuator size	Min. = Min. Max. = Max.	Spring Pre-Loading Spring Pre-Loading	standard		re-inforced		Min		Max					
					Min bar	Max bar	Min bar	Max bar	Supplied Air Pressure (bar)							
									3.0	4.5	6.0	4.5	6.0			
150 6"	60	UV-60 1440 cm ² 223 in ²			380	445	135	0.0	8.2	2.2	15.7	19.2	34.3	49.4	25.3	40.4
					260	304	115	0.0	11.5	3.3	21.9	26.8	47.6	50.0	35.1	50.0
					150	176	90	0.0	19.5	6.0	36.4	44.3	50.0	50.0	50.0	50.0
200 8"	60	UV-60 1440 cm ² 223 in ²			650	761	180	0.0	4.3	0.9	8.6	10.5	19.0	27.5	13.9	22.4
					380	445	135	0.0	8.2	2.2	15.7	19.2	34.3	49.4	25.3	40.4
					260	304	115	0.0	11.5	3.3	21.9	26.8	47.6	50.0	35.1	50.0
250 10"	100	UV-100 1440 cm ² 223 in ²			900	1053	220	0.0	1.2	0.5	2.7	6.9	12.6	18.2	10.7	16.3
					650	761	180	0.0	2.0	0.9	4.3	10.5	19.0	27.5	16.2	24.7
					380	445	135	0.0	4.1	2.2	8.2	19.2	34.3	49.4	29.3	44.3
300 12"	100	UV-100 1440 cm ² 223 in ²			1300	1521	265	0.0	0.7	0.2	1.7	4.6	8.5	12.4	7.2	11.1
					900	1053	220	0.0	1.2	0.5	2.7	6.9	12.6	18.2	10.7	16.3
					650	761	180	0.0	2.0	0.9	4.3	10.5	19.0	27.5	16.2	24.7
350 14"	100	UV-100 1440 cm ² 223 in ²			1800	2106	310	0.0	0.4	0.0	1.2	3.3	6.1	9.0	5.2	8.0
					1300	1521	265	0.0	0.7	0.2	1.7	4.6	8.5	12.4	7.2	11.1
					900	1053	220	0.0	1.2	0.5	2.7	6.9	12.6	18.2	10.7	16.3
400 16"	120	UV-120 1440 cm ² 223 in ²			2500	2925	400				0.0	0.1				
					1800	2106	310				0.0	0.4				
					1300	1521	265				0.0	0.6				

Maximum Allowable Differential Pressure in BAR for Metal Seated Valve with Braided Packings

ECOTROL® 6H PN63, PN100, PN160, PN 250, JIS40K, ANSI 600, ANSI 900, ANSI1500

Flow to open

Actuator Series 812					Action: Air-to-open No. of springs				Action: Air-to-close No. of springs						
Valve body size DN(mm)	Max. travel (mm)	Actuator size	Flow coefficients		Orifice Ø (mm)	3	6	9	12	Supplied Air Pressure (bar)					
			Kv	Cv		bar	bar	bar	bar	3.0	4.5	6.0	4.5	6.0	
25 1"	20 5/8"	MFI-20 320 cm ² 50 in ²	11	12.9	24	27.0	80.1				80.1	160.0	160.0	80.1	160.0
			7	8.2	19	45.9	130.6				130.6	160.0	160.0	130.6	160.0
			4	4.7	16	67.1	160.0				160.0	160.0	160.0	160.0	160.0
			2.5	2.9	11	150.2	160.0				160.0	160.0	160.0	160.0	160.0
			1.6	1.9	9	160.0	160.0				160.0	160.0	160.0	160.0	160.0
40 1 1/2"	20 5/8"	MFI-20 320 cm ² 50 in ²	26	30.4	37	9.5	31.8				31.8	76.4	121.1	31.8	76.4
			18	21.1	32	13.6	43.5				43.5	103.2	160.0	43.5	103.2
			11	12.9	24	27.0	80.1				80.1	160.0	160.0	80.1	160.0
50 2"	30 5/8"	MFI-30 320 cm ² 50 in ²	43	50	48	3.6	16.8				16.8	43.4	69.9	16.8	43.4
			26	30.4	37	7.6	29.9				29.9	74.6	119.2	29.9	74.6
			18	21.1	32	11.2	41.0				41.0	100.7	160.0	41.0	100.7
		MFIII-30 720 cm ² 111 in ²	43	50	48	17.9	45.6	62.1	78.7	52.2	111.9	160.0	55.5	115.2	
			26	30.4	37	31.8	78.3	106.2	134.1	89.5	160.0	160.0	95.0	160.0	
			18	21.1	32	43.5	105.7	143.0	160.0	120.6	160.0	160.0	128.0	160.0	
80 3"	30 1 3/16"	MFI-30 320 cm ² 50 in ²	100	117	73	0.6	6.3				6.3	17.8	29.3	6.3	17.8
			68	80	62	1.4	9.4				9.4	25.3	41.2	9.4	25.3
			43	50	48	3.6	16.8				16.8	43.4	50.0	16.8	43.4
		MFIII-30 720 cm ² 111 in ²	100	117	73	6.8	18.8	25.9	33.1	21.6	47.4	73.2	23.1	48.9	
			68	80	62	10.0	26.6	36.5	46.5	30.6	66.3	102.1	32.5	68.3	
			43	50	48	17.9	45.6	62.1	78.7	52.2	111.9	160.0	55.5	115.2	
100 4"	30 1 3/16"	MFI-30 320 cm ² 50 in ²	150	176	90	0.0	3.8				3.8	11.3	18.8	3.8	11.3
			100	117	73	0.6	6.3				6.3	17.8	29.3	6.3	17.8
			68	80	62	1.4	9.4				9.4	25.3	41.2	9.4	25.3
		MFIII-30 720 cm ² 111 in ²	150	176	90	4.1	11.9	16.6	21.4	13.8	30.8	47.8	14.8	31.7	
			100	117	73	6.8	18.8	25.9	33.1	21.6	47.4	73.2	23.1	48.9	
			68	80	62	10.0	26.6	36.5	46.5	30.6	66.3	102.1	32.5	68.3	
150 6"	60	MFIII-60 720 cm ² 111 in ²	380	445	135	1.0	4.5	6.6	8.6	5.2	12.8	20.3	5.5	13.0	
			260	304	115	1.6	6.4	9.3	12.2	7.5	17.9	28.3	7.9	18.3	
			150	176	90	3.3	11.1	15.9	20.6	12.9	29.8	46.8	13.5	30.5	
200 8"	60	MFIII-60 720 cm ² 111 in ²	650	761	180	0.3	2.2	3.0	3.8	2.7	6.9	11.1	2.8	7.1	
			380	445	135	1.0	4.5	6.6	8.6	5.2	12.8	20.3	5.5	13.0	
			260	304	115	1.6	6.4	9.3	12.2	7.5	17.9	28.3	7.9	18.3	
Actuator Series 811					Spring				Spring						
					standard		re-inforced		Min		Max				
					Min	Max	Min	Max	Supplied Air Pressure (bar)						
										3.0	4.5	6.0	4.5	6.0	
150 6"	60	UV-60 1440 cm ² 223 in ²	380	445	135	0.0	7.5	1.5	15.1	18.6	33.7	48.7	24.6	39.7	
			260	304	115	0.0	10.7	2.4	21.1	25.9	46.7	67.5	34.3	55.1	
			150	176	90	0.0	18.1	4.5	35.0	42.9	76.8	110.8	56.6	90.5	
200 8"	60	UV-60 1440 cm ² 223 in ²	650	761	180	0.0	4.0	0.6	8.2	10.2	18.7	27.1	13.6	22.1	
			380	445	135	0.0	7.5	1.5	15.1	18.6	33.7	48.7	24.6	39.7	
			260	304	115	0.0	10.7	2.4	21.1	25.9	46.7	67.5	34.3	55.1	

* valid for parabolic plug

Maximum Allowable Differential Pressure in BAR for Metal Seated Valve with Braided Packings

ECOTROL® 6N PN10, PN16, PN25, PN40 JIS10K, JIS16K, JIS20K, ANSI 150, ANSI 300

Flow to open

Actuator Series MA41					Action: Air-to-open No. of springs				Action: Air-to-close No. of springs					
Valve body size DN(mm)	Max. travel (mm)	Actuator size	Flow coefficients		Orifice Ø (mm)	1	2	4	-	Supplied Air Pressure (bar)				
			Kv	Cv		bar	bar	bar	bar	1	1	1	2	2
			3.0	4.5		6.0	4.5	6.0						
150 6"	60	MA41C	380	448	135	2,6	6,9	15,6	-	8,8	16,9	25,0	10,4	18,1
			260	304	115	3,8	9,8	21,9	-	12,4	23,6	34,7	14,6	25,3
			150	176	90	6,9	16,7	36,3	-	20,9	39,1	50,0	24,5	41,9
200 8"	60	MA41C	650	761	180	1,2	3,6	8,5	-	4,7	9,2	13,8	5,6	9,9
			380	448	135	2,6	6,9	15,6	-	8,8	16,9	25,0	10,4	18,1
			260	304	115	3,8	9,8	21,9	-	12,4	23,6	34,7	14,6	25,3
250 10"	100	MA41D	650	761	180	-	0,4	2,3	-	3,6	-	-	-	9,2
			380	448	135	-	1,2	4,6	-	6,8	-	-	-	16,9
			900	1053	220	1,4	3,9	6,4	8,7	11,8	18,6	25,4	-	-
300 12"	100	MA41D	1300	1521	265	-	-	0,8	-	1,4	-	-	-	4,0
			900	1053	220	-	0,1	1,4	-	2,2	-	-	-	6,0
			650	761	180	-	0,4	2,3	-	3,6	-	-	-	9,2
350 14"	100	MA41D	1800	2106	310	-	-	0,5	-	0,9	-	-	-	2,8
			1300	1521	265	-	-	0,8	-	1,4	-	-	-	4,0
			900	1053	220	-	0,1	1,4	-	2,2	-	-	-	6,0
Actuator Series MA60					Action: Air-to-open No. of springs				Action: Air-to-close No. of springs					
Valve body size DN(mm)	Max. travel (mm)	Actuator size	Flow coefficients		Orifice Ø (mm)	2	4	6	8	Supplied Air Pressure (bar)				
			Kv	Cv		bar	bar	bar	bar	3.0	4.5	6.0	4.5	6.0
			3.0	4.5		6.0	4.5	6.0						
150 6"	60	MA3.60A 2185 cm ² 339 in ²	380	445	135	4,7	11,8	18,8	25,9	26,7	46,2	50,0	36,5	50,5
			260	304	115	6,8	16,5	26,2	36,0	37,1	50,0	50,0	40,1	50,0
			150	176	90	11,7	27,6	43,5	50,0	50,0	50,0	50,0	50,0	50,0
200 8"	60	MA3.60A 2185 cm ² 339 in ²	650	761	180	2,4	6,4	10,3	14,3	14,7	25,7	36,5	20,2	31,0
			380	445	135	4,7	11,8	18,8	25,9	26,7	46,2	50,0	36,5	50,0
			260	304	115	6,8	16,5	26,2	36,0	37,1	50,0	50,0	40,1	50,0
250 10"	100	MA3.60D 2185 cm ² 339 in ²	900	1053	220	1,1	3,4	5,6	7,9	7,3	13,8	20,1	9,3	15,9
			650	761	180	1,8	5,3	8,7	12,1	11,2	20,8	30,6	14,1	24,0
			380	445	135	3,8	9,8	15,9	22,0	20,4	37,5	50,0	25,6	43,1
300 12"	100	MA3.60D 2185 cm ² 339 in ²	1300	1521	265	0,6	2,2	3,8	5,3	4,9	9,4	13,9	6,3	10,8
			900	1053	220	1,1	3,4	5,6	7,9	7,3	13,8	20,1	9,3	15,9
			650	761	180	1,8	5,3	8,7	12,1	11,2	20,8	30,6	14,1	24,0
350 14"	100	MA3.60D 2185 cm ² 339 in ²	1800	2106	310	0,4	1,5	2,7	3,8	3,5	6,8	10,1	4,5	7,8
			1300	1521	265	0,6	2,2	3,8	5,3	4,9	9,4	13,9	6,3	10,8
			900	1053	220	1,1	3,4	5,6	7,9	7,3	13,8	20,1	9,3	15,9
400 16"	120	MA3.60D 2185 cm ² 339 in ²	2500	2925	400	0,0	0,5	1,0	1,5	1,6	3,5	5,3	2,0	3,8
			1800	2106	310	0,1	1,0	1,8	2,7	2,8	6,0	9,1	3,4	6,6
			1300	1521	265	0,2	1,4	2,6	3,8	4,0	8,3	12,5	4,8	9,1

Maximum Allowable Differential Pressure in BAR for Metal Seated Valve with Braided Packings

ECOTROL® 6H PN63, PN100, PN160, PN250, JIS40K, ANSI 600, ANSI 900, ANSI1500

Flow to open

Actuator Series MA41					Action: Air-to-open No. of springs				Action: Air-to-close No. of springs					
Valve body size DN(mm)	Max. travel (mm)	Actuator size	Flow coefficients		Orifice Ø (mm)	Supplied Air Pressure (bar)								
			Kv	Cv		2	6	10	14	2	2	2	6	6
						bar	bar	bar	bar	3.0	4.5	6.0	4.5	6.0
50 2"	30	MA41A6	43	50	48	14,1	58,9	104,2	149,5	95,6	160,0	160,0	99,8	160,0
			26	30,4	37	25,3	100,7	160,0	160,0	160,0	160,0	160,0	160,0	160,0
			18	21,1	32	34,8	135,6	160,0	160,0	160,0	160,0	160,0	160,0	160,0
80 3"	30	MA41A6	100	117	73	5,1	24,5	44,1	63,7	40,4	69,3	98,3	42,2	70,7
			68	80	62	7,1	34,6	61,7	88,9	56,6	96,7	136,8	59,1	98,6
			43	50	48	14,1	58,9	104,2	149,5	95,6	160,0	160,0	99,8	160,0
100 4"	30	MA41A6	150	176	90	3,0	15,7	28,6	41,5	26,1	45,2	64,2	27,4	46,1
			100	80	62	5,1	24,5	44,1	63,7	40,4	69,3	98,3	42,2	70,7
			68	50	48	7,7	34,6	61,7	88,9	56,6	96,7	136,8	59,1	98,6

Actuator Series MA41					Action: Air-to-open No. of springs				Action: Air-to-close No. of springs					
Valve body size DN(mm)	Max. travel (mm)	Actuator size	Flow coefficients		Orifice Ø (mm)	Supplied Air Pressure (bar)								
			Kv	Cv		1	2	4	-	1	1	1	2	2
						bar	bar	bar	bar	3.0	4.5	6.0	4.5	6.0
150 6"	60	MA41C6	380	448	135	2,4	6,7	15,4	-	8,6	16,7	24,7	10,2	17,9
			260	304	115	3,7	9,9	22,4	-	12,6	24,1	35,7	14,9	25,9
			150	176	90	6,4	16,2	35,8	-	20,5	38,6	56,8	24,0	41,4
200 8"	60	MA41C6	650	761	180	1,2	3,9	9,3	-	5,1	10,0	15,0	6,0	10,8
			380	448	135	2,4	6,7	15,4	-	8,6	16,7	24,7	10,2	17,9
			260	304	115	3,7	9,9	22,4	-	12,6	24,1	35,7	14,9	25,9

Actuator Series MA60					Action: Air-to-open No. of springs				Action: Air-to-close No. of springs					
Valve body size DN(mm)	Max. travel (mm)	Actuator size	Flow coefficients		Orifice Ø (mm)	Supplied Air Pressure (bar)								
			Kv	Cv		2	4	6	8	2	2	2	4	4
						bar	bar	bar	bar	3.0	4.5	6.0	4.5	6.0
150 6"	60	MA3.60A 2185 cm ² 339 in ²	380	445	135	3,5	10,5	17,6	24,6	25,4	45,0	64,2	35,2	54,4
			260	304	115	5,1	14,8	24,5	34,3	35,3	62,3	88,8	48,8	75,3
			150	176	90	8,9	24,8	40,7	56,6	58,3	102,3	145,5	80,3	123,5
200 8"	60	MA3.60A 2185 cm ² 339 in ²	650	761	180	1,7	5,6	9,6	13,6	14,2	25,0	35,8	19,5	30,3
			380	445	135	3,5	10,5	17,6	24,6	25,4	45,0	64,2	35,2	54,4
			260	304	115	5,1	14,8	24,5	34,3	35,3	62,3	88,8	48,8	75,3

* valid for parabolic plug

Dimensions and Weights

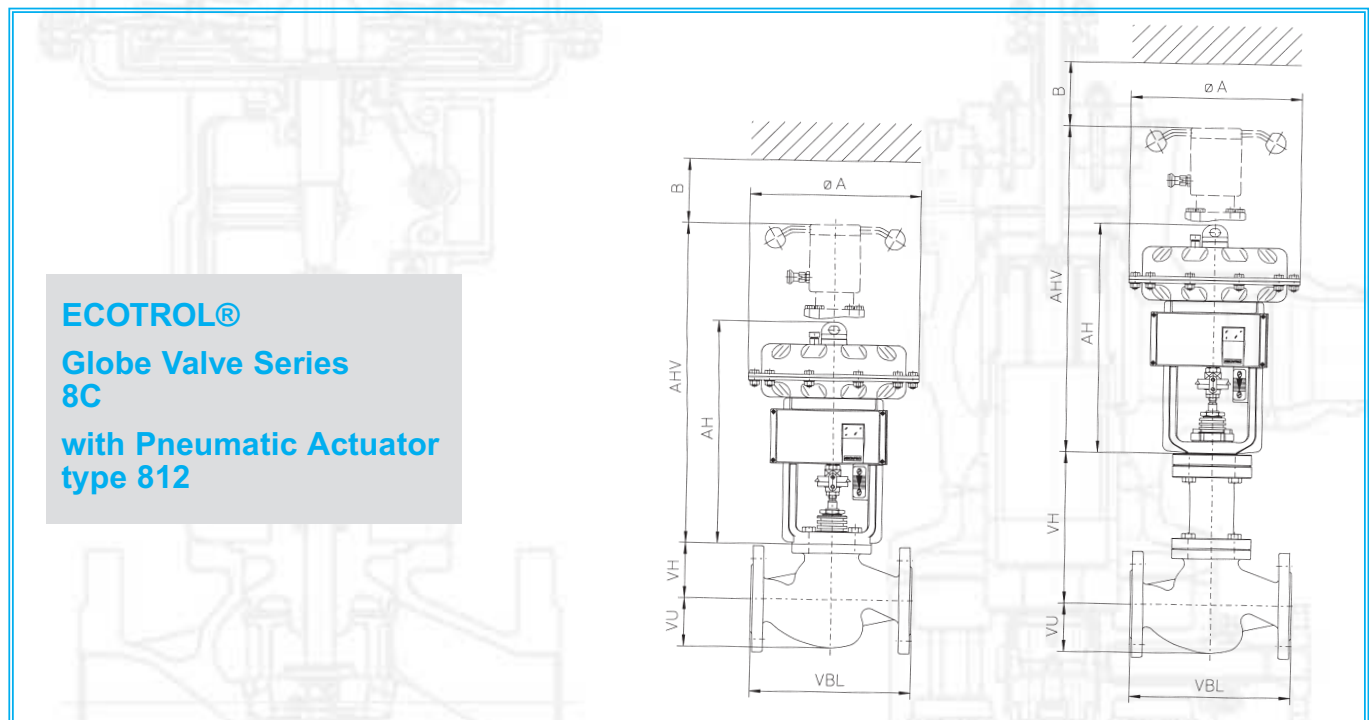

Principal dimensions (in mm) for flanged bodies acc. to EN 1092-1 (DIN 2533/2534/2543/2545)											
Face-to-face dimensions acc. to DIN EN 60534-3-1 (DIN EN 558)											
Valve Type 8C	DN	15	20	25	32	40	50	65	80	100	
	VBL	130	150	160	180	200	230	290	310	350	
	VH	DEK1	114				105			156	181
		DEK2	170				167			248	267
		DEK3	170				167			248	267
		DEK4	228				233			365	389
		DEK5	on request								
		DEK6	75				87			-	-
		DEK7								196	221
		DEK8								261	286
VU	48	59	62	70	78	83	93	106	136		
Actuator Type 812	ØA	MF I	270								
		MF III								400	
	AH	MF I	346							404	
		MF III								489	
	AHV	MF I	493							551	
		MF III								651	
	B	130							150		
	Weight approx. kg	MF I	20.5	22.5	23	24	31	33	41.5	70	93
MF III									96	119	

* Weight: valve (DN15-65 with DEK6 / DN80-100 with DEK1) + actuator without handwheel

Dimensions and Weights

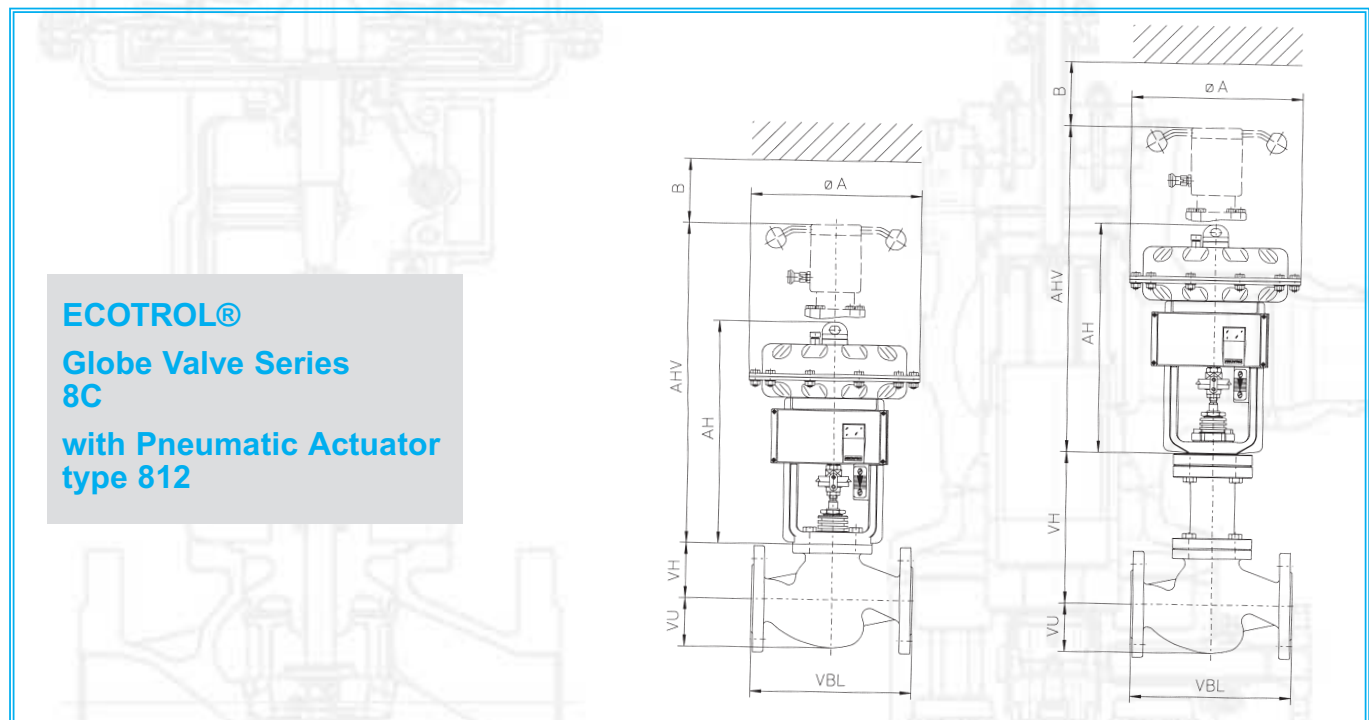

Principal dimensions (in mm) for flanged bodies acc. to ANSI class 150/300 RF/RTJ										
Valve Type 8C	DN		1/2"	3/4"	1"	1 1/2"	2"	3"	4"	
	VBL	RF	178	181	184	222	254	298	352	
		RTJ	-	-	197	235	267	311	365	
	VBL	RF	190	194	197	235	267	317	368	
		RTJ	202	206	210	248	282	333	384	
	VH	DEK1	114			105			156	181
		DEK2	170			167			248	267
		DEK3	170			167			248	267
		DEK4	228			233			365	389
		DEK5	on request							
DEK6		75			87			-	-	
DEK7								196	221	
DEK8								261	286	
VU		48	59	62	78	83	106	136		
Actuator Type 812	ØA	MF I	270							
		MF III							400	
	AH	MF I	346							404
		MF III								489
	AHV	MF I	493							551
		MF III								651
	B		130							150
	Weight approx. kg	MF I	20.5	22.5	23	31	33	70	93	
MF III								96	119	

* Weight: valve (DN15-50 with DEK6 / DN80-100 with DEK1) + actuator without handwheel

Dimensions and Weights

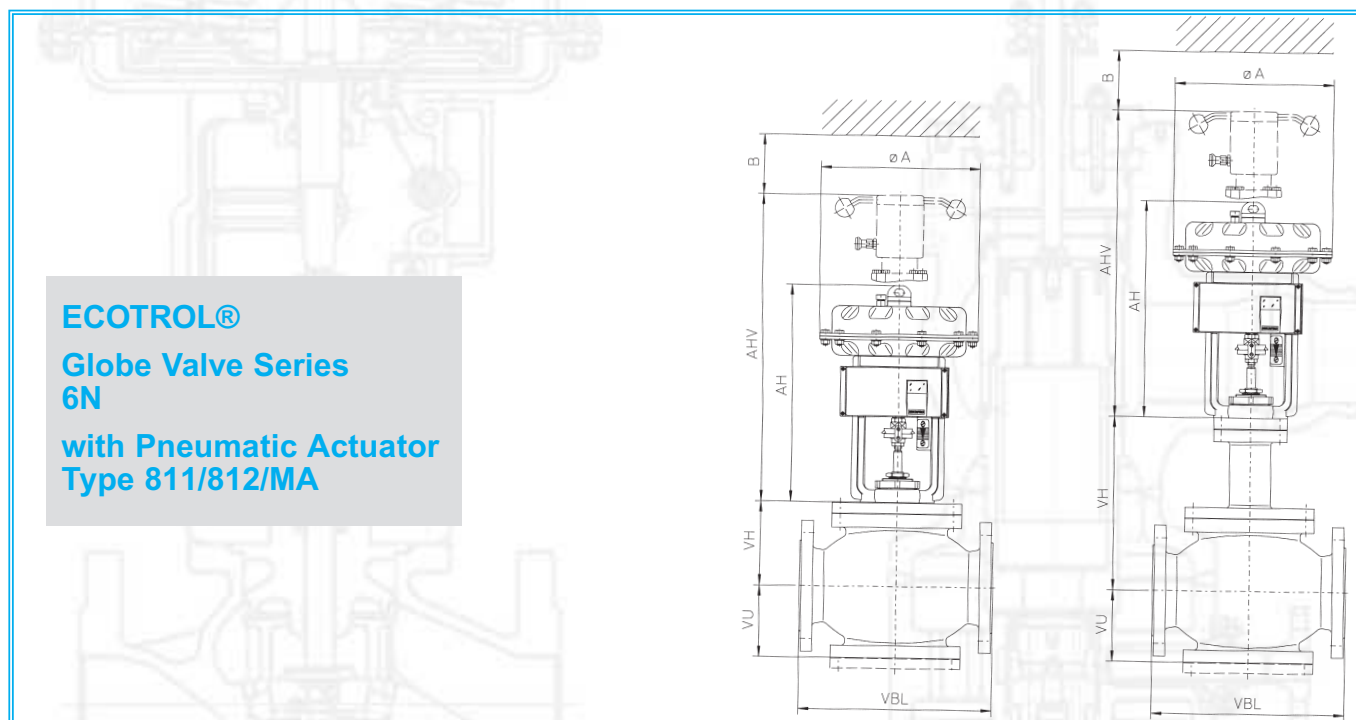

Principal dimensions (in mm) for flanged bodies acc. to EN 1092-1 (DIN 2533/2534/2543/2545)										
Face-to-face dimensions acc. to DIN EN 60534-3-1 (DIN EN 588)										
Valve Type 6N	DN		150	200	250	300	350	400		
	VBL		480	600	730	850	980	1150		
	VH	DEK1		260	292	357	394	462	518	
		DEK2		355	407	506	543	611	667	
		DEK3		355	407	506	543	611	667	
		DEK4	on request							
		DEK5	on request							
		DEK7		260	292	357	394	462	518	
DEK8		355	407	506	543	611	667			
VU	3FL		189	239	305	335	395	443		
Actuator Type 811/812/MA	ØA	MFIII	400							
		UV					530			
		MA.60					596			
	AH	MFIII	625							
		UV	1006						1135	
		MA.60	840				1010		1080	
	AHV	MFIII	888							
		UV	1323						1452	
	B		200						340	
	Weight approx. kg	MFIII	190	250						
UV		225	285	355	655	745	1395			
MA.60		330	390	450	750	840	1490			

Dimensions and Weights

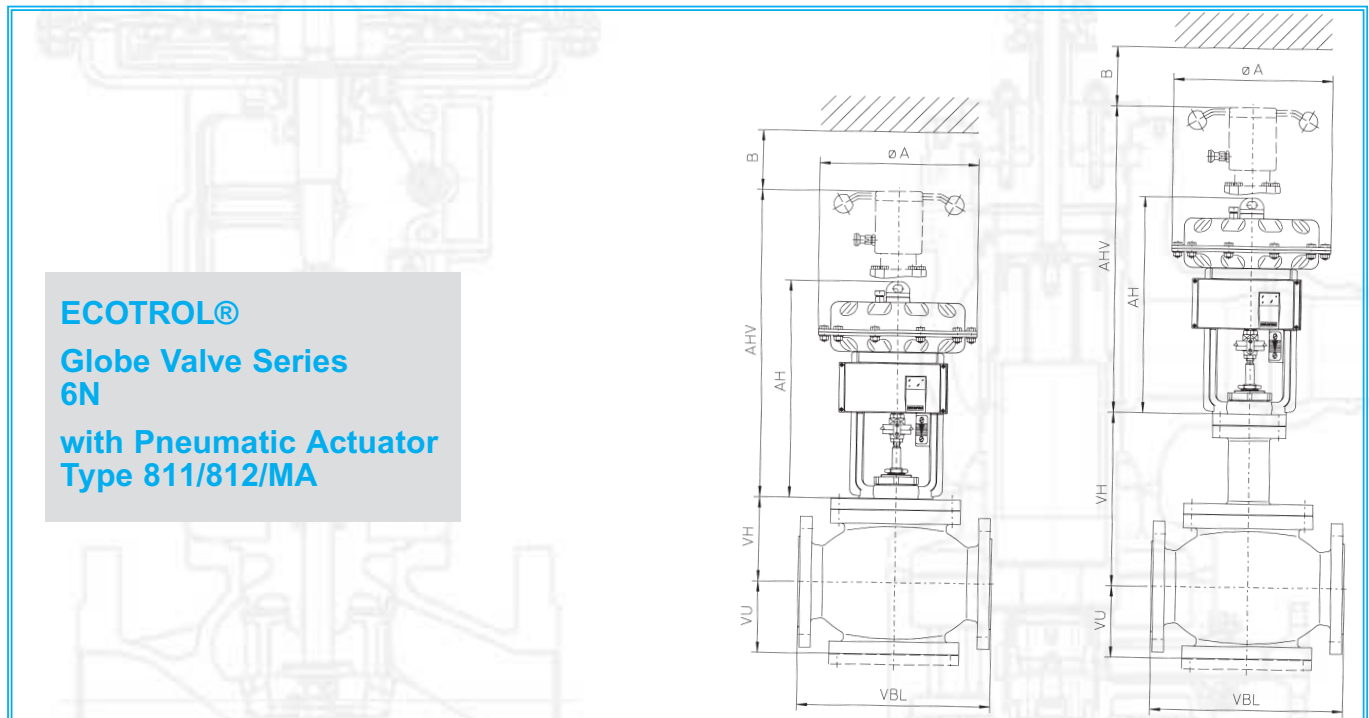

Principal dimensions (in mm) for flanged bodies acc. to ANSI Class 150/300 RF/RTJ									
Valve Type 6N	DN		6"	8"	10"	12"	14"	16"	
	VBL*	RF	451	543	730 (673)	850 (737)	980 (889)	1150 (1016)	
		Cl. 150 RTJ	464	556	730 (686)	850 (750)	993 (902)	1150 (1029)	
	VBL*	RF	473	568	730 (708)	850 (775)	980 (927)	1150 (1057)	
		Cl. 300 RTJ	489	584	730 (724)	850 (791)	996 (943)	1073	
	VH	DEK1	260	292	357	394	462	518	
		DEK2	355	407	506	543	611	667	
		DEK3	355	407	506	543	611	667	
		DEK4	on request						
		DEK5	on request						
DEK7		260	292	357	394	462	518		
DEK8		355	407	506	543	611	667		
VU	3FL	189	239	305	335	395	443		
Actuator Type 811/812/MA	ØA	MFIII	400						
		UV	530						
		MA.60	596						
	AH	MFIII	625						
		UV	1006		1135				
		MA.60	840		1010		1080		
	AHV	MFIII	888						
		UV	1323		1452				
	B		200		340				
	Weight approx. kg	MFIII	190	250					
UV		225	285	355	655	745	1395		
MA.60		330	390	450	750	840	1490		

* size 6" to 8" acc. to ANSI B16.10 (section control) - size 10" to 16" acc. to DIN EN 60534-3-1 (DIN EN 558)
 () dimensions in brackets are in preparation / others are available

Dimensions and Weights

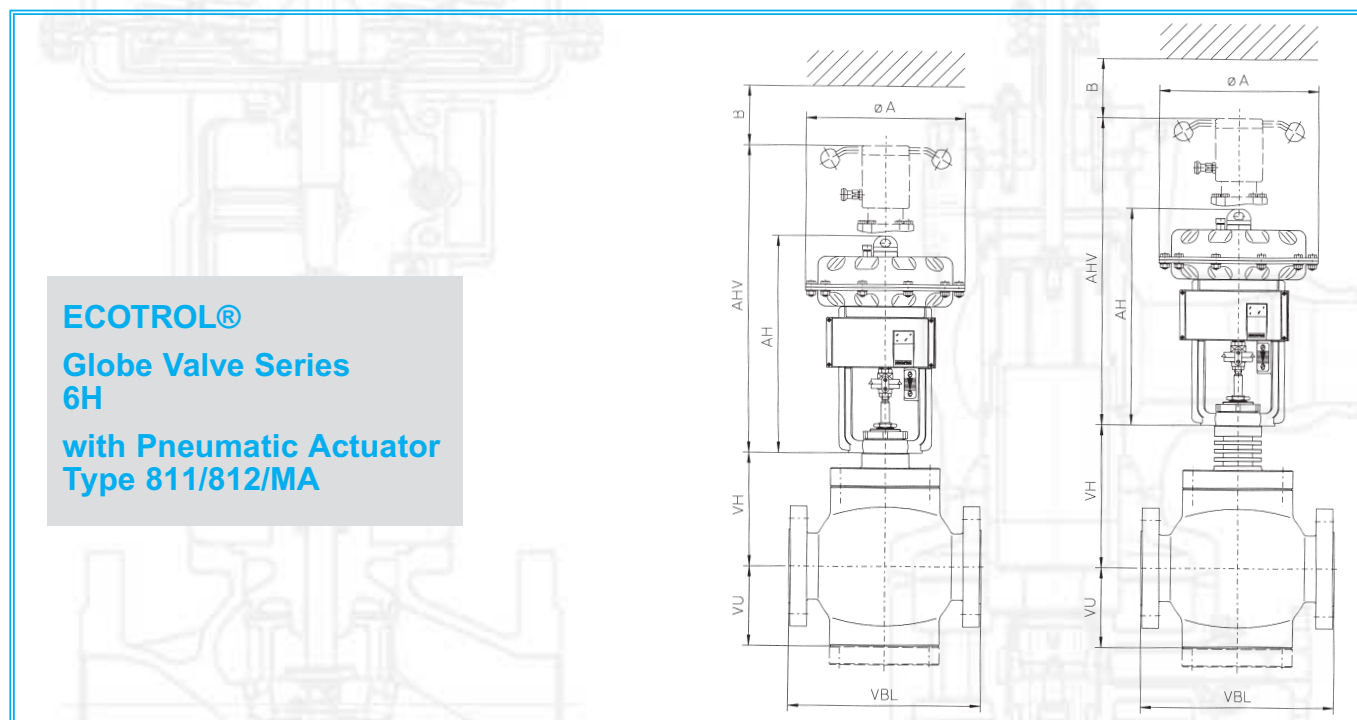

Principal dimensions (in mm) for flanged bodies acc. to EN 1092-1 (DIN 2546/2547/2548)
Face-to-face dimensions acc. to DIN 3202-F2

Valve Type 6H	DN	25	40	50	80	100	150	200	
	VBL	230	260	300	380	430	550	700*	
VH	DEK1	132	159	178	220	255	342	357	
	DEK2	167	239	243	300	332	402	447	
	DEK3	167	239	243	300	332	402	447	
	DEK4	on request							
	DEK5	on request							
	DEK7				220	255	342	357	
	DEK8				300	332	402	447	
VU	3FL	68	103	113	153	178	228	260	
	4FL			174	219	254	314	366	
Actuator Type 811/812/MA	ø A	MF I	270						
		MF III					400		
		UV					530		
		MA.60					596		
	AH	MF I	361					625	
		MF III				489		625	
		UV					1006		
		MA.60					840		
	AHV	MF I	508					888	
		MF III				657		888	
		UV					1323		
	B	130					200		
	Weight approx. kg	MF I	34	42	72	101	136		
MF III					98	127	162	317	607
UV								335	645
MA.60								460	750

* not acc. to DIN 3202-F2

Dimensions and Weights

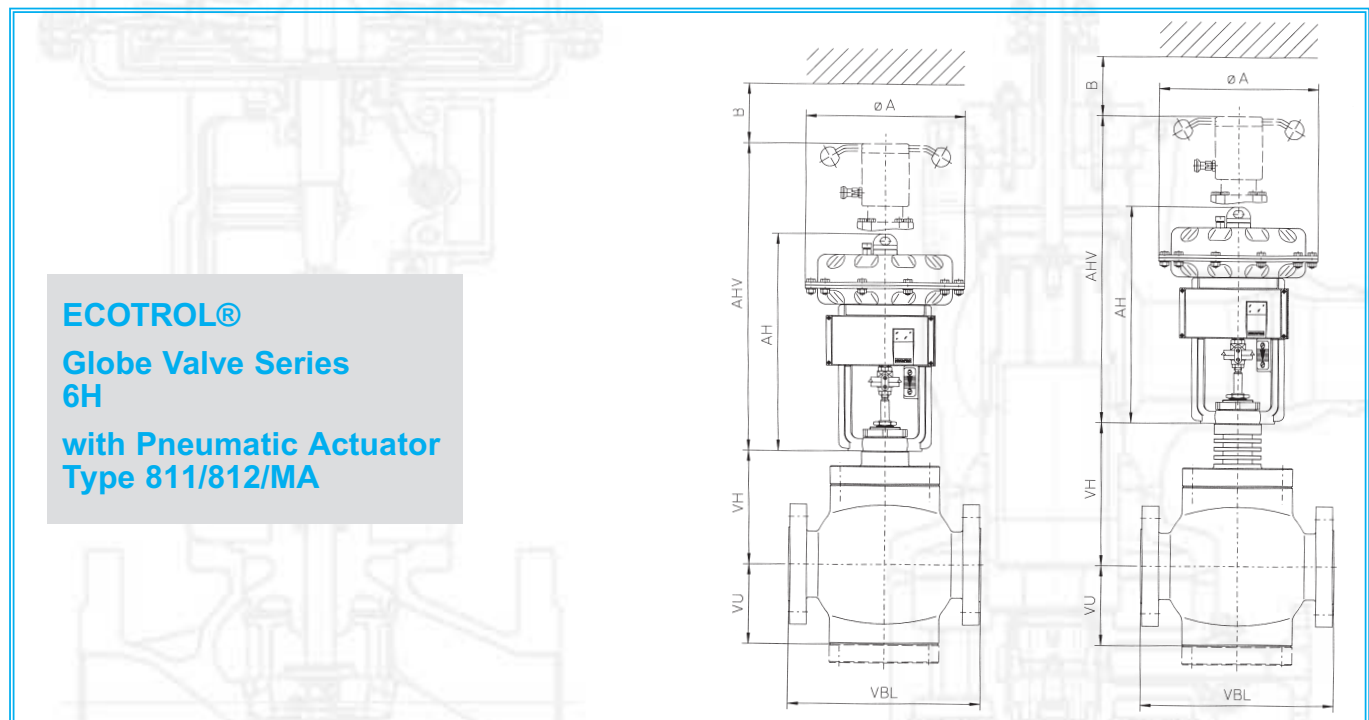

Principal dimensions (in mm) for flanged bodies acc. to ANSI Class 600/900/1500 RF/RTJ											
Valve Type 6H	DN		1"	1 1/2"	2"	3"	4"	6"	8"		
	VBL	RF		216	241	292	356	432	559	660	
RTJ			216	241	295	359	435	562	664		
Cl. 600	RF		254	305	368	381	457	610	737		
	RTJ		254	305	372	384	460	613	740		
VBL	RF		on request								
	RTJ		on request								
VH	DEK1		132	159	178	220	255	342	357		
	DEK2		167	239	243	300	332	402	447		
	DEK3		167	239	243	300	332	402	447		
	DEK4		on request								
	DEK5		on request								
	DEK7					220	255	342	357		
	DEK8					300	332	402	447		
	VU	3FL		68	103	113	153	178	228	260	
4FL					174	219	254	314	366		
Actuator Type 811/812/MA	ØA	MFI	270								
		MFIII					400				
		UV							530		
		MA.60							596		
	AH	MFI	361								
		MFIII					489		625		
		UV							1006		
	AHV	MA.60							840		
		MFI	508								
		MFIII					657		888		
	B	UV							1323		
			130						200		
Weight approx. kg		MFI	34	42	72	101	136				
		MFIII					98	127	162	317	607
		UV							335	645	
		MA.60							460	750	

Useful Tables/Conversions & Applicable Standards

Size	Symbol	Unit	Unit	Unit	Unit	Unit
Length	l s	1 m	1000 mm	39.37 in	3.28 ft	
Area	A	1 m ²	1550 in ²	10.764 ft ²		
Volume	V	1 m ³	61020 in ³	35.32 ft ³	220 Impgal	264 US gal
Vol. Rate Flow	Q	1 m ³ /h	16.7 l/min	0.589 ft ³		4.41 GMP
Mass Flow	G	1 m ³ /h x ρ				
Flow Coefficient		1 kv	1.16 cv			
Density	ρ	1 kg/m ³	36.1x10 ⁻⁶ lb/cu.in	0.0624 lb/cu.ft		
Temperature	T	0 K	-273°C	-273 x 9/5 + 32F 0 x 9/5 + 32F		
Mass	m	1 kg	2.204 lb	35.273 oz		
Force	F	1 N	0.102 kp	0.225 lbf		
Pressure	p	10 ⁵ Pa	1 bar	14.5 lb/in ²		
Power	P	1 kw	860 kcal/h	1.34 hp		
Viscosity	η	1 Pa x s	1 Ns/m ²	1 x 10 ⁴ Stoke		

Prefix	Symbol	Factor	Equivalent Number
nano	n	10 ⁻⁹	one-billionth
micro	μ	10 ⁻⁶	one-millionth
milli	m	10 ⁻³	one-thousandth
kilo	k	10 ³	one thousand
mega	M	10 ⁶	one million
giga	G	10 ⁹	one billion
tera	T	10 ¹²	one trillion

Standards

DIN EN	1349	Industrial process control valves
DIN EN	558	Face-to-face dimensions for flanged valves
DIN EN	1092-1	Flanges, types of contact faces
DIN EN	1092-2	Dimensions of cast iron flanges PN16 and PN25
DIN EN	1092-1	Dimensions of cast steel flanges PN16, 25, 40, 63, 100, 160 and 250
DIN IEC	534 T4	Industrial process control valves - Inspection and routine testing
DIN IEC	534 T6	Industrial process control valves - Mounting details for attachments of positioner to control valve actuator
ASME	B16.5	Flange dimensions for Cl.150, 300, 600, 900 and 1500 flanges (RF, RTJ)
ASME	B16.25	Valves - flanged and buttwelding ends

Testing

Unmachined Material	NDT in accordance with the applicable technique following of the order specification	DIN EN 10213 DIN EN 12266
Finished Component	visual testing hydrostatic test of all pressure containing parts (1,5 x PN)	AD 2000 A4 6.1 AD 2000 A4 6.3 DIN EN 12266
Completed Valve	testing of order inspection testing of execution and surface testing of marking testing of actuator function testing of valve travel	DIN EN 12266 DIN EN 12266 DIN EN 12266 DIN EN 12266 DIN EN 12266

Notes

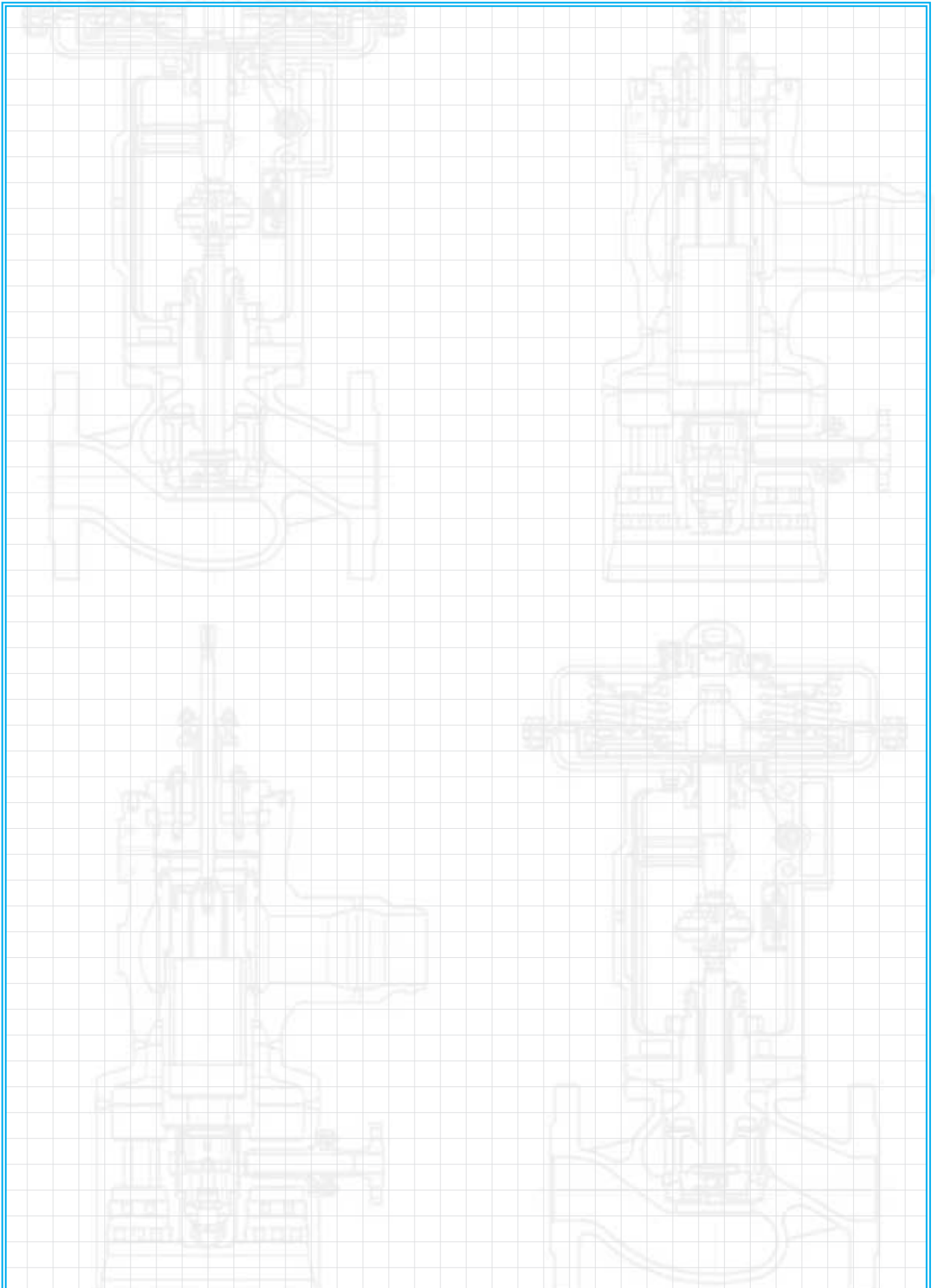



world-wide

Germany



ARCA Regler GmbH

Kempener Strasse 18
47918 Toenisvorst
GERMANY
Phone: ++49-2156-7709-0
Fax: ++49-2156-770950...55
eMail: sale@arca-valve.com
www.arca-valve.com

ARTES Valve & Service GmbH

Pankow Park
Lessingstrasse 79
13185 Berlin
GERMANY
Phone: ++49-30-912047-10
Fax: ++49-30-912047-20
eMail: info@artes-valve.de
www.artes-valve.de

FELUWA Pumpen GmbH

Beulertweg
54570 Mürtenbach
GERMANY
Phone: ++49-6594-10-0
Fax: ++49-6594-1640
eMail: info@feluwa.de
www.feluwa.de

Switzerland



Von Rohr Armaturen AG

Fichtenhagstr. 4
4132 Muttenz
SWITZERLAND
Phone: ++41-61-4614848
Fax: ++41-61-4611827
eMail: info@von-rohr.ch
www.von-rohr.ch

WEKA AG

Schürlistrasse 8
8344 Baeretswil
SWITZERLAND
Phone: ++41-43-8334343
Fax: ++41-43-8334329
eMail: info@weka-ag.ch
www.weka-ag.ch

The Netherlands



Von Rohr ARCA BV

Postbus 138
6960 AC Eerbeek
THE NETHERLANDS
Phone: ++31-313-654000
Fax: ++31-313-655581
eMail: info@vonrohr-arca.nl

India



Forbes Marshall ARCA Ltd

A-34/35 M.I.D.C., Industrial Area
H Block, Pimpri
411018 Pune
INDIA
Phone: ++91-20-7442020
Fax: ++91-20-7442040
eMail: vsk@forbesmarshall.com
www.forbesmarshall.com

Korea



SAM YANG ARCA Co. Ltd.

No. 48-14 Samjung-Dong
Bucheon-Si
Kyung Gi Do
SOUTH KOREA
Phone: ++82-32-6786390
Fax: ++82-32-6783124
eMail: arcako@unitel.co.kr

P.R. China



Wuzhong Instrument Co. Ltd.

67, Chaoyang Street
Litong District
751100 Wuzhong City
P.R. CHINA
Phone: ++86-953-2069086
Fax: ++86-953-2069084
eMail: wy@mail.wzyb.com.cn

Mexico



ARCA Valvulas S.A. de C.V.

Oaxaca 507
Col. Francisco J. Mina
Tampico, Tamaulipas
MEXICO
Phone: ++52-5-55575861
Fax: ++52-5-55806346
eMail: arca@axtel.net

European Representatives in:

Austria • Belgium • Czech Republic • Denmark • Finland • France • Greece • Great Britain • Hungary • Ireland • Italy • Norway • Poland • Portugal • Rumania • Russia • Spain • Sweden • Slovakia

Non-European Representatives in:

Australia • Iran • Israel • Japan • New Zealand • Pakistan • Syria • Taiwan • Turkey • VAE • Venezuela

For detailed information (name and addresses), please contact us!
DS ECOTROL-gb

