

Installation instructions for:
Impedance pipe probes type TSS 80 DN* SF
TSS 80 DN* SF MTI*/**FIX**



The best measure



Pipe Probe TSS 80 SF

TREINA Electronics AG

Pipe probe with coax connection (impedance measure)

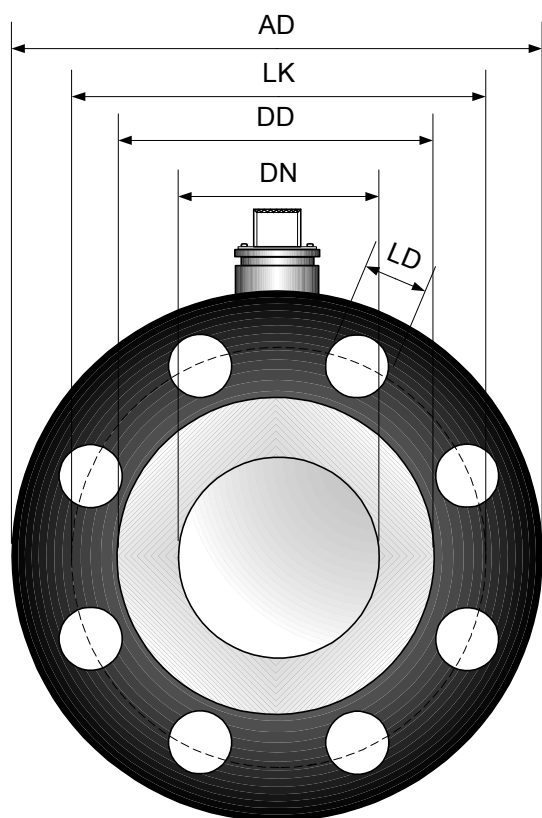

Use:

After separators/decanter, built into pipe line for the batch phase separation of liquid products
 chemicals / solvents / full-empty switch on reactor drain / pipe line monitoring

Probe structure:

- Probe body with optimized corrosion protection
- Parts in contact with product: full PTFE element
- Probe mounting height 70 – 92 mm
- Must be mounted with additional flat seals
- Coax connection to external MTI
- Measuring electronic (as complete system) calibrated at factory, no probe calibration required

Temperature range:

–20 up to +170 °C Medium

Connection:

full/empty level switch measuring units
 coax cable 0.3 m / MTI 50/1 DG
 coax cable 1.0 m / MTI 50/2 DG
 Universal measuring unit QTI 800 K
 coax cable 0.3 m / MTI 50/1 AG
 coax cable 1.0 m / MTI 50/2 AG

coax cable 2/3 m / MTI 50/ 4/6 AG

Caution: cable drift (2/3 m) in function of temperature, usage only at constant environment temperature

Article-No.:

02.29.11.8020 /30/40/50/80/100

Probe type according to type code:

Example:	TSS	80	DN80	SF
----------	-----	----	------	----

Your version:	TSS	80		SF
---------------	-----	----	--	----

Pipe probe version:

TSS	= pipe probe	TSS		
80	= Teflon PTFE body element	80		

Probe mount flange size:

DN40	= flange DN 32/40 PN 16 form G, flat	
DN50	= flange DN 50 PN 16 form G, flat	DN50
DN80	= flange DN 80 PN 16 form G, flat	
DN100	= flange DN 100 PN 16 form G, flat	
ANSI	= flange ANSI 2" 150 lbs. form G, flat	
ANSI	= flange ANSI 3" 150 lbs. form G, flat	

SF	= connection to steel flange	
	> see probe specs	SF



Pipe Probe TSS 80 SF MTI FIX

TREINA Electronics AG

Pipe probe with fix mounted measuring electronic (impedance measure)

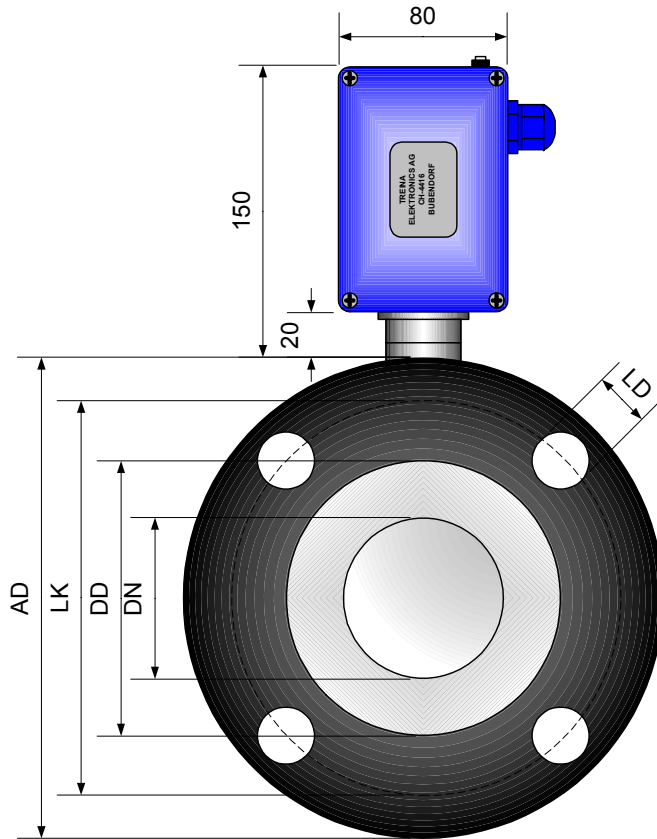

Use:

After separators/decanter, built into pipe line for the batch phase separation of liquid products chemicals / solvents / full-empty switch on reactor drain / pipe line monitoring

Probe structure:

- Probe body with optimized corrosion protection
- Parts in contact with product: full PTFE element
- Probe mounting height 70 – 92 mm
- Must be mounted with additional flat seals
- Measuring electronic rotatable 360°
- Measuring electronic calibrated at factory, no probe calibration required

Temperature range:

- -20 up to +100 °C Medium
- -20 up to + 60 °C connection head
- Medium up to 170 °C: Probe version with coax cable

Connection:

Universal measuring unit QT1 800 K
 full/empty level switch measuring units

Article-No.:

02.29.11.0000

Probe type according to type code:

Example:	TSS	80	DN50	SF	MTI	50/0	A	G	2	FIX
Your version:	TSS	80		SF	MTI		A	G		FIX
Pipe probe version:										
TSS	= pipe probe	TSS								
80	= Teflon PTFE body element	80								
Probe mount flange size:										
DN40	= flange DN 32/40 PN 16 form G, flat									
DN50	= flange DN 50 PN 16 form G, flat		DN50							
DN80	= flange DN 80 PN 16 form G, flat									
DN100	= flange DN 100 PN 16 form G, flat									
ANSI	= flange ANSI 2" 150 lbs. form G, flat									
ANSI	= flange ANSI 3" 150 lbs. form G, flat									
SF	= connection to steel flange			SF						
	> see probe specs									
On site measuring electronic:										
MTI	= measuring electronic insert, angular				MTI					
50/0	= measuring range for interfacial layer, full/empty switch					50/0				
20/0	= measuring range for product monitoring, concentration measures									
A	= analogue measuring technique for interfacial layer, monitoring, concentration						A			
D	= digital technique for full/empty switch									
G	= measuring electronic in protection housing IP 65 blue, powder coated							G		
0	= without protection for hazardous area									
2	= with protection for hazardous area EEx ia T6 IIC / CE								2	
Fix	= Fix connection MTI rotatable 360°									Fix



Pipe Probe TSS 80 SF K MTI FIX

TREINA Electronics AG

Pipe probe with fix mounted measuring electronic (impedance measure) with temperature decoupling

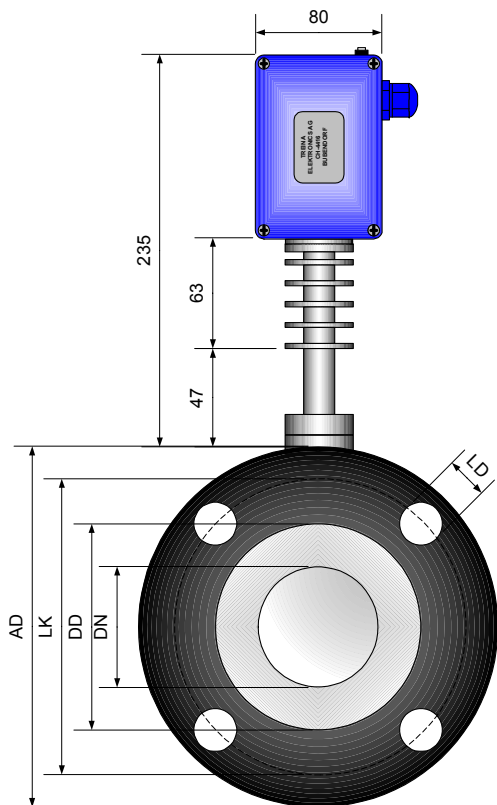

Use:

After separators/decanter, built into pipe line for the batch phase separation of liquid products
 chemicals / solvents / full-empty switch on reactor drain / pipe line monitoring

Probe structure:

- Probe body with optimized corrosion protection
- Parts in contact with product: full PTFE element
- Probe mounting height 70 – 92 mm
- Must be mounted with additional flat seals
- Measuring electronic rotatable 360°
- Measuring electronic calibrated at factory, no probe calibration required

Temperature range:

- -20 up to +170 °C Medium
- -20 up to + 60 °C connection head

Connection:

Universal measuring unit QTI 800 K
 full/empty level switch measuring units

Article-No.: 02.29.11.0000

Probe type according to type code:

Example:	TSS	80	DN50	SF	K	MTI	50/0	A	G	2	FIX
Your version:	TSS	80		SF	K	MTI		A	G		FIX
Pipe probe version:											
TSS	= pipe probe	TSS									
80	= Teflon PTFE body element	80									
Probe mount flange size:											
DN40	= flange DN 32/40 PN 16 form G, flat										
DN50	= flange DN 50 PN 16 form G, flat		DN50								
DN80	= flange DN 80 PN 16 form G, flat										
DN100	= flange DN 100 PN 16 form G, flat										
ANSI 2"	= flange ANSI 2" 150 lbs. form G, flat										
ANSI 3"	= flange ANSI 3" 150 lbs. form G, flat										
SF	= connection to steel flange			SF							
	> see probe specs										
Cooling gills element for high temperature probes:											
K	= with cooling gills element				K						
On site measuring electronic:											
MTI	= measuring electronic insert, angular					MTI					
50/0	= measuring range for interfacial layer, full/empty switch						50/				
20/0	= measuring range for product monitoring, concentration measures										
A	= analogue measuring technique for interfacial layer, monitoring, concentration							A			
D	= digital technique for full/empty switch										
G	= measuring electronic in protection housing IP 65 blue, powder coated								G		
0	= without protection for hazardous area										
2	= with protection for hazardous area EEx ia T6 IIC / CE									2	
FIX	= Fix connection MTI rotatable 360 °										FIX



Pipe Probe TSS 80 SF KS MTI FIX

TREINA Electronics AG

Pipe probe with fix mounted measuring electronic (impedance measure) with temperature decoupling. Version KS for pipelines with outside linings

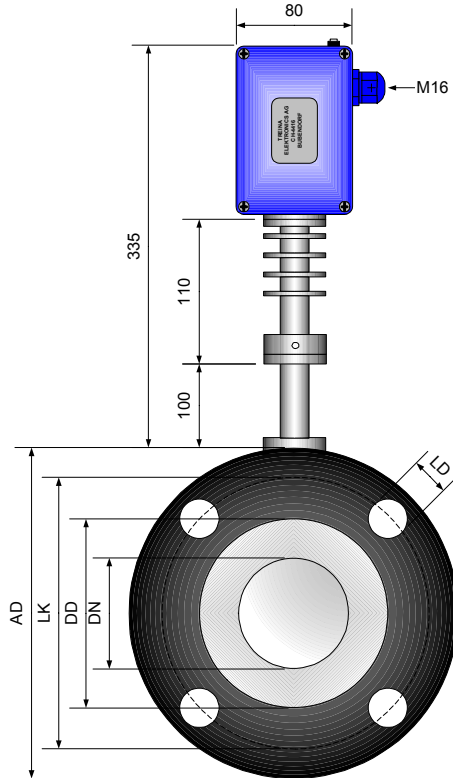

Use:

After separators/decanter, built into pipe line for the batch phase separation of liquid products
 chemicals / solvents / full-empty switch on reactor drain / pipe line monitoring

Probe structure:

- Probe body with optimized corrosion protection
- Parts in contact with product: full PTFE element
- Probe mounting height 70 – 92 mm
- Must be mounted with additional flat seals
- Measuring electronic rotatable 360°
- Measuring electronic calibrated at factory, no probe calibration required
- KS versions with extended cooling gills connection element for pipe lines with outside (insulating) linings

Temperature range:

- –20 up to +170 °C Medium
- –20 up to + 60 °C connection head

Connection:

Universal measuring unit QTI 800 K
 full/empty level switch measuring units

Article-No.: 02.29.11.0000. ...

Probe type according to type code:

Example:	TSS	80	DN50	SF	KS..	MTI	50/0	A	G	2	FIX
Your version:	TSS	80		SF	KS	MTI	50/0	A	G	2	FIX
Pipe probe version:											
TSS	= pipe probe	TSS									
80	= Teflon PTFE body element	80									
Probe mount flange size:											
DN40	= flange DN 32/40 PN 16 form G, flat										
DN50	= flange DN 50 PN 16 form G, flat		DN50								
DN80	= flange DN 80 PN 16 form G, flat										
DN100	= flange DN 100 PN 16 form G, flat										
ANSI 2"	= flange ANSI 2" 150 lbs. form G, flat										
ANSI 3"	= flange ANSI 3" 150 lbs. form G, flat										
SF	= connection to steel flange			SF							
	> see probe specs										
Cooling gills element for high temperature probes:											
K/KS...	= with cooling gills element (KS... = extended cool. gills element)				KS						
On site measuring electronic:											
MTI	= measuring electronic insert, angular				MTI						
50/1	= measuring range for interfacial layer, full/empty switch					50/					
20/1	= measuring range for product monitoring, concentration measures										
A	= analogue measuring technique for interfacial layer, monitoring, concentration						A				
D	= digital technique for full/empty switch										
G	= measuring electronic in protection housing IP 65 blue, powder coated							G			
0	= without protection for hazardous area										
2	= with protection for hazardous area EEx ia T6 IIC / CE									2	
FIX	= Fix connection MTI rotatable 360°										FIX



Assembling instruction for pipe probes TSS 80 DN . . SF and with fix mounted MTI measuring electronic

1. To observe at installation

1.1. Before and during installation

- The pipe probes TSS 80 must be protected against humidity and mechanical damages before and during installation.
- Remove the blue shrinkable sleeve from the coaxial connector of the pipe probe only at connection of the coaxial cable (Version with separated MTI)

1.2. Mounting position

- Mounting position from 1 % pipe inclination up to vertical, depending on application.
- The pipe probe empty drain off must be assured; Commissioning – Checklist for interfacial layer measure with pipe probes, must be observed.
- Mounting direction independent of flow direction.
- Mounting between 2 flat flanges PN 16 / 150 lbs with 2 seals (2 mm each)
Caution! Observe the flange distance for the different nominal diameter as well as the sealing instructions described in chapter 2.
- The flat seals protect the PTFE body/lining and assure the impermeability.
- The PTFE body/lining element protrudes 0.5 mm on each side.
Caution! The 2 inner O-ring assures a 100% impermeability only once the probe is built in.
- The black probe body is optimally protected against corrosion. Avoid damaging the protection coating.
- At installation of the probe to a pipe without outer isolation, possibility is given to mount the measuring electronic (MTI) with a bracket directly to the flange.

1.3. Dimension of the TSS 80 pipe probes

Nominal diameter/ø	AD	DN	LD bore holes	LK	DD	mounting h	FLA including seals
DN 32/40	150	40	8 x ø 18	100/110	77	70	74
DN 50	165	50	4 x ø 18	125	97	92	96
DN 80	200	80	8 x ø 18	160	123	74	78
DN 100	220	100	8 x ø 18	180	146	74	78
ANSI 2"	152.4	50	4 x ø 19.1	120.7	97	92	96
ANSI 3"	190.5	80	4 x ø 19.1	152.4	123	74	78

1.4. Electrical connection of the pipe probe.

1.4.1. Earthing the pipe probe

- Earth terminals to be connected to a metallic pipe (4 mm² Cu-cable); Equipotential bond
- With system made out of glass, earth rings can be mounted and connected to the earth terminals
- Connect pipe probe earth terminals to equipotential bond

Reason: Regulation for hazardous area SEA / ATEX
 Fault free operation in steel, enamel and glass systems



1.4.2. Coaxial cable connection (version with separate MTI)

1. Remove the blue shrinkable sleeve from the coaxial connector of the pipe probe
 2. The connection of the pipe probe to the measuring electronic to be done with an original coaxial cable (manufactured ready to connect)
 3. Slide the 2 black shrinkable sleeves over the coaxial connectors on each side of the cable.
 4. Screw the 2 coaxial connectors to pipe probe and measuring electronic (tighten securely by hand)
 5. Slide shrinkable sleeve over coaxial connector and sealing ring with groove and shrink evenly with hot air blower
- The tight shrink sleeves protects the connector from splash water and corrosion.

1.4.3. Connecting the MTI measuring electronic to the control unit

1. Connection in 2-wire technique (1 x 2 x 0.75 mm²) shielded
2. The shield to be earth grounded on 1 or better on both sides (EMC)
3. Use end splice for the non-isolated cable end
4. Proceed as per accompanying wiring diagram of the systems

1.4.4. Assembly of system components

Pipe probe	coax cable	measuring electronic	microprocessor	Application
TSS 80 DN .. SF	2.0/3.0 m	TSE 80	TSK 80	interfacial layer
	0.3m	MTI 50/1 AG	QTI 800 K / 801 S1/2	
	1.0 m	MTI 50/2 AG		
	2.0 m	MTI 50/4 AG		
	3.0 m	MTI 50/6 AG	VTI 300 K / LTI 200 K	full / empty
	0.3 m	MTI 50/1 DG		
	1.0 m	MTI 50/2 DG		
	2.0 m	MTI 50/4 DG		
3.0 m	MTI 50/6 DG			

TSS 80 DN .. SF MTI FIX	-	MTI 50/0 AG	QTI 800 K	interfacial layer
TSS 80 DN .. SF K MTI FIX		MTI 20/0 AG	QTI 801 S1/2	concentration
		MTI 50/0 DG	VTI 300 K / LTI 200 K	full / empty

2. Torque values for TSS 80 pipe probes

2.1. Material of seals

No	Seal	Supplier	surface pressure [N/mm ²]		
			min	recommended	max
1	Gylon Standart	Kubo Tech	20	25	35
2	Gylon blue	Kubo Tech	10	15	35
3	UCAR 323	Angst+Pfister	20	28	35

- The max. surface pressure values were taken into consideration up to 200°C.
- The limit for using PTFE is at about 50 N/mm²; however with a quite strong cold flow.
- Our values are 30% below, therefore the cold flow is significantly reduced

2.2. Thread coefficient of friction

The coefficient of friction for stainless steel bolt connections is, without lubrication, between 0.23 – 0.5 and 0.10 – 0.20 with MoS2 lubricant. In reason of the low torque and reduced scoring tendency, all our indications are related to lubricated stainless steel bolts connections with an average coefficient of friction of 0.



2.3. Bolt connection, material and sizes

In reason of the pretension we recommend the use of stainless steel bolts of the solidity class 70 – 80

Nominal diameter of pipe probe:	DN 32 – 50	4 bolts M 16
	DN 80 – 100	8 bolts M 16
	ANSI 2"– 3"	4 bolts M 18
	(ANSI 4"	8 bolts M 18)

2.4. Sealing surface

TSS 80 DN 32/40	2 x 3150 mm ²
TSS 80 DN 50 / ANSI 2"	2 x 5100 mm ²
TSS 80 DN 80 / ANSI 3"	2 x 6350 mm ²
TSS 80 DN 100/ (ANSI 4")	2 x 8250 mm ²

Formula for pretension (FV [N]) per bolt:

$$FV \text{ [kN]} = \text{surface pressure [kN/mm}^2] \times \text{sealing surface [mm}^2] / \text{quantity of bolts}$$

Example TSS 80 DN 50, seal material Gylon blue, minimal surface pressure

$$0.01 \text{ kN/mm}^2 \times 5100 \text{ mm}^2 / 4 = \underline{12.75 \text{ kN}}$$

2.5. Torque

The torque is determined with the conversion factor (Bosshard table), taking into consideration the coefficient of friction of the pretension

conversion factor M 16: 0.0030

conversion factor M 18: 0.0034

2.6. Mounting instructions

Tighten the bolts crosswise with 50% of the nominal torque. With 80% at the second tightening and apply the full torque at the third. Check after 24 hours to eventually compensate seal setting

2.7. Type of seal

With connection (flared flange a.s.o.) which does not lay on/cover the entire Teflon surface of the pipe probe, or in case of non-flat surface like on enameled flanges, steel core seals must be used.

e.g. PTFE seals with integrated steel disc, 3 mm thick, plus above and below, 1 each Gylon seal

2.8. Torque table

Probe type TSS 80...	Seal 1 Torque [Nm]			Seal 2 Torque [Nm]			Seal 3 Torque [Nm]		
	min	<i>recommended</i>	max	min	<i>recommended</i>	max	min	<i>recommended</i>	max
DN 32/40 SF	48	60	84	24	36	84	48	68	84
DN 50 SF	78	98	137	40	60	137	78	110	137
DN 80 SF	48	60	84	24	36	84	48	68	84
DN 100 SF	62	78	109	31	47	109	62	87	109
ANSI 2"SF	88	110	154	44	66	154	88	124	154
ANSI 3" SF	104	135	189	54	81	189	104	151	189
(ANSI 4" SF)	70	88	123	35	53	123	70	98	123



2.9. Installation of the pipe probes

The installation, with protection rings, of pipe probes in enameled or coated piping

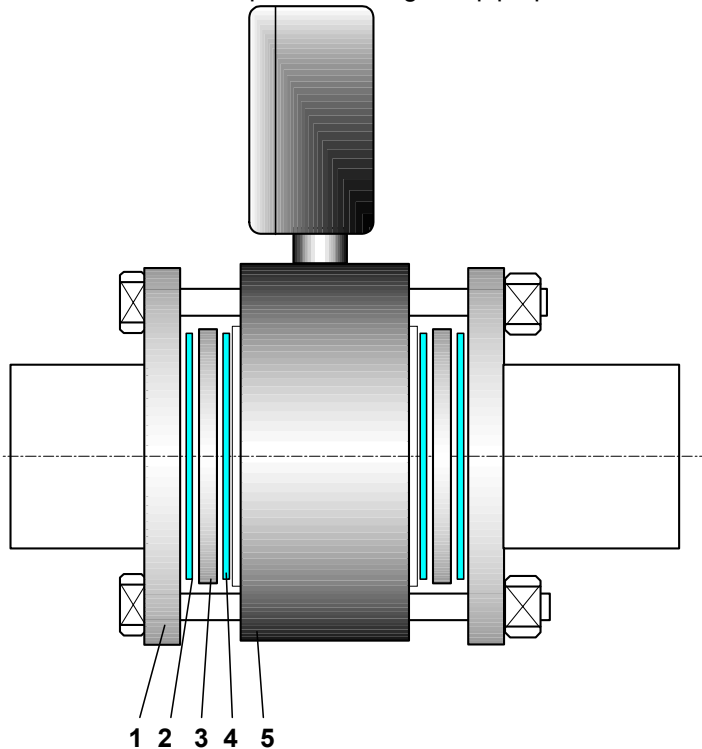

1. Flange DN/ANSI ... PN..
2. Seal for pipe probe "Gylon"
3. Protection ring for pipe probe
material: SS 1.4435/PTFE covered
4. Seal for pipe probe "Gylon"
5. Pipe probe TSS80

2.10. Note

At probe mounting do not exceed the recommended torque in order to optimally preserve the PTFE probe lining. Excess torque leads to deformation of probe inner body/lining.

2.11. Notice to liability and warranty claims

Liability and warranty claims are excluded at non appropriate handling of the probe, like:

- opening of the probe threaded joint
- mechanical act upon probe body or PTFE body/lining element, like drilling, milling, or similar
- non conform installation and/or electrical connections
- use of non appropriate mounting material like seals, mounting bolts, or similar
- repair through third party
- connection to third party equipment
- non appropriate use referring to specifications as i.e. pressure, temperature and products
- non conform disposal

2.12. Not an equipment element for pressure safety control function

On the installation side the process measurement might require an additional pressure safety device

3. Uninstallation of pipe probes:

- Empty pipe line and rinse with nitrogen or water as per operation instructions (observe internal safety instructions)
- Uninstall pipe probe
- Build in the new pipe probe as per installation instructions (observe internal safety instructions for opened pipe lines)



4. Certifications / Tests:

4.1. Pressure Equipment Directive

- PED Pressure Equipment directive 97/23/EG category II module A1
- Test report no. P-CH-SVTI-02-05-35614-001 **CE 0036**

4.2. ATEX

- Hazardous area certification as per directive 94/9EG (ATEX 100 A)
Design type test certificate SNCH 02 ATEX 3357 X
confidential test report no. 01-IK-0330.01 **CE 0499**

4.2.1. Description

The interfacial layer pipe probes of the type series TSS *****; MTI***/* or FIX* with separate measuring electronic (MTI) or fix mount connection (FIX) is in connection with the control unit type .TI...K or ...S (SEE99 ATEX 2469), used as signal acquisition of the different product phases (batch phase separation) in the hazardous area (observe MTI datasheet)

Hazardous area classification:  **II 1/2 G EEx ia IIC T6**

4.2.2. Condition of use for pipe probes group II category 1 zone 0

1. The pipe probe Treina of the type series TSS** with fix mounted impedance measuring electronic type MTI ***/* (FIX*) or separated measuring electronic can be used, as per EN 60079-14:1997 in the category 2 and in the category 3 (zone 1 and zone 2) as well as in the gas groups IIA, IIB and IIC which are explosion endangered by combustible substances in the range of the temperature classes T1 up to T6.
2. Only the sensor in contact with the products of the pipe probe Treina of the type series TSS** can be used in zone 0 and must be included in the periodical pressure test of the pipe line.
3. As per EN 50284 chapter 4.4 Avoidance of an electrostatic charging on PTFE coated electrodes in pipelines by non conductive, blowby medium (electrical conductivity $<10^{-9}$ S/m) the following is valid:

Zone 0 gas group IIA / IIB no restriction coating s < 2 mm

Classification C:

hydrogen	H ₂
acetylene	C ₂ H ₂
carbon bisulphide	CS ₂

Zone 0 gas group IIA / IIB and IIC when pipe is inertised

When the liquids have an electric conductivity of $>10^{-9}$ S/m, so that an electrostatic charging of the PTFE inner body is, also in rare abnormal occurrences, impossible, then no restriction applies to zone 0

The indication on the equipment type plate must be observed

4. As the probe electrical circuit is on earth on the plant side, a common equipotential bond must exist in the entire wiring of the electrical probe wiring and in the supply and signal electrical circuit (inside and outside of the hazardous area).

